



Republic of the Philippines
DEPARTMENT OF EDUCATION



K to 12 Basic Education Curriculum Technology and Livelihood Education Learning Module



DRESSMAKING/ TAILORING

EXPLORATORY COURSE

Grade 7 and Grade 8

TABLE OF CONTENTS

	Page
What is this Module About?	2
How do you Use this Module	3
LESSON 1 – Use of Sewing Tools	4-22
LESSON 2 – Carry Out Measurements and Calculations	23-51
LESSON 3 – Create Design for a Simple Project	52-73
LESSON 4 – Perform Basic Maintenance	74-102
LESSON 5- Practice Occupational Safety and Health	103-123
Answer Keys.....	124-130
Acknowledgment	131



What Is This Module About?

Welcome to the world of ***Dressmaking/Tailoring!***

This Module is an exploratory and introductory course on **Dressmaking and/or Tailoring** which leads you to **Dressmaking/Tailoring** National Certificate Level II (NC II)¹. It covers **5** common competencies in **Dressmaking/Tailoring** that a Grade 7/Grade 8 Technology and Livelihood Education (TLE) student like you ought to possess, namely:

- 1) Use of sewing tools;
- 2) Carry out measurements and calculations;
- 3) Create design for simple project;
- 4) Perform basic maintenance, and
- 5) Practice occupational safety and health

These **5** common competencies are covered separately in 5 Lessons. As shown below, each Lesson is directed to the attainment of one or more learning outcomes:

Lesson 1 – **Use of sewing tools**

Learning Outcomes (LO) 1 Identify sewing tools and equipment and their uses

Lesson 2 – **Carry out measurements and calculations**

Learning Outcomes (LO) 1 Obtain measurements

Learning Outcomes (LO) 2 Perform simple calculations

Learning Outcomes (LO) 3 Estimate appropriate quantities

Lesson 3 – **Create design for simple project**

Learning Outcomes (LO) 1 Sketch simple project design

Learning Outcomes (LO) 2 Produce simple project

Lesson 4 – **Perform basic maintenance**

Learning Outcomes (LO) 1 Operate machine and assess its performance

Learning Outcomes (LO) 2 Clean and lubricate machine

Lesson 5 – **Practice Occupational Safety and Health**

Learning Outcomes (LO) 1 Identify and evaluate hazards and risks

Learning Outcomes (LO) 2 Control hazards and Risks

¹**NATIONAL CERTIFICATE (NC)** is a certification issued to individuals who achieved all the required units of competency for a national qualification as defined under the Training Regulations. NCs are aligned to specific levels within the PTQF. (**TESDA Board Resolution No. 2004-13, Training Regulations Framework**)

NATIONAL CERTIFICATE LEVEL refers to the four (4) qualification levels defined in the Philippine TVET Qualifications Framework (PTQF) Where the worker in:

a. **NC I** performs a routine and predictable tasks; has little judgment; and, works under supervision;

b. **NC II** performs prescribe range of functions involving known routines and procedures; has limited choice and complexity of functions, and has little accountability;



How Do You Use This Module?

This Module has 5 Lessons. Each Lesson has the following:

- Learning Outcomes
- Performance Standards
- Materials/Resources
- Definition of Terms
- What Do You Already Know?
- What Do You Need to Know?
- How Much Have You Learned?
- How Do You Apply What You Learned?
- How Well Did You Perform? (Scoring Rubric)
- What is your Score?
- How Do You Extend Your Learning?
- References

To get the most from this Module, you need to do the following:

1. Begin by reading and understanding the Learning Outcome/s and Performance Standards. These tell you what you should know and be able to do at the end of this Module.
2. Find out what you already know by taking the Pretest then check your answer against the Answer Key. If you get 99 to 100% of the items correctly, you may proceed to the next Lesson. This means that you need not go through the Lesson because you already know what it is about. If you failed to get 99 to 100% correctly, go through the Lesson again and review especially those items which you failed to get.

Do the required Learning Activities. They begin with one or more Information Sheets. An Information Sheet contains important notes or basic information that you need to know. After reading the Information Sheet, test yourself on how much you learned by means of the Self-check. Refer to the Answer Key for correction. Do not hesitate to go back to the Information Sheet when you do not get all test items correctly. This will ensure your mastery of basic information.

3. It is not enough that you acquire content or information. You must be able to demonstrate what you learned by doing what the Activity / Operation /Job Sheet directs you to do. In other words, you must be able to apply what you have learned in real life.
4. How well did you perform? Accomplish the Scoring Rubrics.

Each Lesson also provides you with references and definition of key terms for your guide. They can be of great help. Use them fully



If you have questions, don't hesitate to ask your teacher for assistance.

LESSON 1

Use of Sewing Tools



LEARNING OUTCOMES:

At the end of this Lesson, you are expected to do the following:

LO 1. Identify sewing tools and equipment are identified



Definition of Terms

- Altering** - changing portion of a garment so that it fits the body.
- Cutting tools** - a cutting implement; a tool for cutting.
- Fabric** - the cloth used in making garments.
- Measuring tools** - an instruments used for obtaining quantities, dimensions or forces of real world objects.
- Sewing Machine** - a textile machine used to stitch fabric, cards and other material with thread.
- Sewing Tools** - instruments that aid in accomplishing a sewing task

LEARNING OUTCOME 1

Identify sewing tools and equipment and their uses

PERFORMANCE STANDARDS

- Sewing tools and equipment are identified
- Types of sewing machines are classified and their uses are identified



Materials

Measuring Tools
Cutting Tools
Pinning Tools
Marking Tools
Sewing Machines
Fabrics
Thread



What Do You Already Know?

Let us determine how much you already know about the use of sewing tools and equipment. Take this test.

Pretest LO 1

Direction: Read each item carefully and choose the letter of the best answer from the choices below. Write your answer in your quiz notebook.

1. A machine that is run by foot which may also be converted to electric power machine is known as _____.
 - a. hemmer machine
 - b. high speed over edger
 - c. lockstitch machine
 - d. over edging machine
2. The mechanism that sets the sewing machine in motion.
 - a. balance wheel
 - b. belt
 - c. feed dog
 - d. stitch regulator
3. The part of the sewing machine that controls the looseness and tightness of Stitches.
 - a. bobbin
 - b. thread guide
 - c. presser foot
 - d. upper tension
4. The appropriate cutting tool used in cutting fabrics.
 - a. Trimming shears
 - b. Pinking shears
 - c. Dressmaker bent handled shears
 - d. buttonhole scissors
5. A flexible tape with different type of measurements essential for taking body measurements.
 - a. ruler
 - b. tape measure
 - c. yard stick
 - d. hem gauge
6. It measures 12 -18 inches and can be used for drawing straight lines and cutting lines
 - a. yardstick
 - b. button hole scissor
 - c. ruler
 - d. French curve
7. This is used to shape the depth of the neckhole and armhole of the pattern.
 - a. French curve
 - b. ruler
 - c. tape measure
 - d. trimming scissor
8. This is also called "Domestic Sewing Machine".
 - a. Lockstitch sewing machine
 - b. Double needle sewing machine
 - c. Hi-speed sewing machined.
 - d. Button holer machine
9. A small hard pitted cup worn for protection on the finger that pushes the needle in sewing.
 - a. thimble
 - b. sewing gauge
 - c. seam ripper
 - d. fabric
10. This is used in reinforcing the opening and closing of pockets
 - a. Bartacking machine
 - b. Embroidery machine
 - c. Hi-speed locked machine
 - d. Sewing machine



What Do You Need To Know?

Read the Information Sheet 1.1 very well then find out how much you can remember and how much you learned by doing Self-check 1.1.

Information Sheet 1.1

Sewing Tools and Equipment



Sewing equipment different tools are used in garment construction. The skillful use of the different sewing equipment will help take body measurement and drafting pattern with accuracy and speed.

Success in sewing calls for the right tools at the right time. All tools must be appropriate in a proper order and one must know how to use them to save time

and produce the best result.

This lesson will provide knowledge and skills of the different tools and equipment which are necessary in sewing. A complete set of sewing tools and equipment are presented to help the students work faster.

MEASURING TOOLS

Tape Measure

A flexible measuring device used in taking body measurements. The front has the measurement of 150 centimeters and 60 inches on the other side. Fiberglass tape is commonly used by dressmakers.



Sewing Gauge

A small ruler with a sliding guide and is about six inches long. This gauge is used for measurements at hem lines, button holes and areas where other small measurements require checking, such as pleats and tucks. The gauge is usually made of metal or plastic.

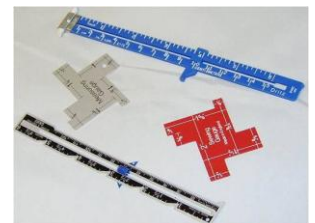

Rulers

A ruler measuring 12 inches or even 18 inches, either clear or solid. It is a useful tool to have for measuring and drawing straight seam lines and cutting lines. It also aids in connecting lines. A clear ruler is also a good tool for marking buttonholes.



Yardstick

A yardstick is made of smooth, shellacked hardwood or metal. It is used for marking hemlines and checking grainlines when laying out the pattern.



L-square

The **tailor square** or "L" is used to transfer measurements to the draft pattern. It also divides the garment into the desired measurement. It has perfect squares and is useful in making straight lines and numbers. It can also function as a tape measure.

It has two arms connected perpendicularly.

- a. The longer arm is twenty-four (24) inches long.
- b. The shorter arm is fourteen (14) inches long.



French Curve

This is used to shape the depth of the neckhole and armhole of the pattern.



CUTTING TOOLS

Cutting tools are instruments that serve well if properly maintained. Sharp cutting tools make clean cuts and well-defined notches and they do not damage fabric. On the other hand, dull tools slow the cutting process, and make your hand and wrist tire easily. Sewing cutting tools should not be used for other household task. Cutting tools must be sharpened regularly and the joints are oiled occasionally for better use.

Bent-handled dressmaker's shears

These are made of quality steel and hold a sharp cutting edge. The blades move easily and cut smoothly along the entire length and the points should come together. Shears have the length of 7- 12 inches and are satisfactory for most apparel fabrics.

- a. All steels, chrome-plated shears are for heavy duty cutting
- b. Stainless steel blades and plastic handles are fine for lightweight fabrics
- c. A serrated edge shears give maximum cutting control and is used for synthetic fibers and slippery knits



Pinking Shears

This is popular in zigzagging or scalloped edge or for seam finishes. This is used to finish seams and raw edges and to create decorative edges on many types of fabric. It cuts a ravel-resistant edge. This is not satisfactory



for straight cutting.

Cutting scissors

a. Trimming scissor

It is 3-4 inches long. It is used for trimmings, clipping threads and snipping slashes.



b. Embroidery scissor

It has 4-5 inches finely tapered blades. Both points are sharp for use in working with fine details in delicate fabrics and in embroidery work.

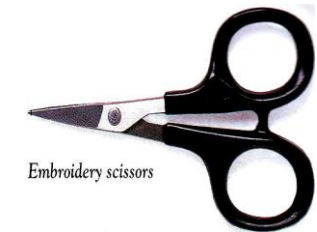

c. Buttonhole scissor

This is intended for making buttonholes.



Thread Clippers

Thread clippers are a handy little spring loaded cutting tool that allows for the snipping of threads. These clippers are specifically used to snip threads and they are not designed to cut fabric.



Seam Ripper

Seam rippers are specifically designed for ripping out stitches from seams, either as a result of an error or during alterations. They should be used carefully to prevent damage to the fabric.



Rotary Cutter and Mat

It is an adaptation of the giant rotary cutter used by the garment industry. It works like a pizza cutter and can be used by left or right-handed sewers. The rotary cutter is available in different sizes with different blades. When using a rotary cutter, work on a cutting mat to protect the blade and the cutting surface.



MARKING TOOLS

Marking tools are required for transferring pattern markings to garment fabric pieces and for making alterations on garments.



Chalk Pencils/Dressmaker pencil

This is available in white or pastel shades. This chalk pencil is used to make fine lines on fabric. It has an erasing brush at one end.



Liquid Marking Pen

Liquid marking pens come in two types. There is one that washes out and one that fades after 48 hours. Those that wash out should not be used on fabric that show water marks. The mark should be removed before pressing the fabric.



Tailor's Chalk

This is essential as a marker for use on materials. Tailor's chalk is available in a range of colors and is removed by brushing.

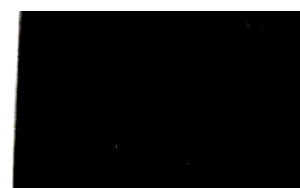

Wax chalk

Wax chalk

This is available in black or white and is used for woolen fabrics. Wax can be removed by pressing.

Tracing Wheel

There are two types of tracing wheels, those with a serrated edge and those with a smooth edge. The serrated edge wheel produces dots on the fabric and is suitable for most types of fabrics. The smooth edge wheel is best for delicate fabrics and unlike the serrated edge will not pierce more delicate fabrics. The smooth edge wheel creates a solid line.



Dressmaker's Carbon Paper

Dressmaker's carbon paper also called dressmaker's tracing paper is a specially waxed carbon paper that transfers the tracing wheel's markings to the fabric. A color of tracing paper should be chosen that is close to the color of the fabric. Different brands of



tracing paper have different instructions; therefore, the instructions for the particular brand that is purchased should be followed.

PINNING AND SEWING TOOL

Pincushion

A pincushion holds the straight pins and needles while working to prevent accidents.



Hand Needle

Used in making temporary stitches and buttonholes. Sizes of 7 to 10 are for general hand sewing.



Sewing Needle Threader

It aids in putting the thread to the needle. It consists of two parts. The handle and the wire. The end of the wire that is away from the holder is folded. Place the folded wire of the needle threader through the eye of the sewing needle.



Thimble

A small hard pitted cup worn for protection on the finger that pushes the needle in [sewing](#).



MATERIALS



Fabric

The **Fabric** is the cloth used in making garments. The plain cotton fabrics, flour sack or catcha is the most appropriate material for beginners because these are very easy to handle.



Thread

The **thread** is used in assembling or constructing the parts of the garment. Threads vary in sizes. Heavy fabrics need stronger threads. Threads should have the same color with that of the fabric used.

Types of Sewing Machines

Well-selected sewing machine is essential for achieving good results. It should be used correctly in accordance with the job requirements.

1. **Lockstitch Sewing Machine.** This is usually used in homes and sometimes in school. This is also called “Domestic Sewing Machine”. It is run by foot and may also be converted to electric power machine.



2. **Hi-Speed Lockstitch Sewing Machine.** This is sometimes called „straight stitching machine” or industrial sewing machine. It has automatic lubrication and is used by tailors and dressmakers.



3. **Over Edging Machine.** Other companies call it “small machine”. It finishes the raw edges of the pattern for construction.



4. **Embroidery Machine.** This is used in making fancy stitches and in making different kinds of embroidery stitches on fabrics for the Barong Tagalog, pillow cases, linen, and other novelty items.



5. **Button Holer Machine.** This is used in making buttonholes on garments.



6. **Button Attachment Machine.** This is used in attaching buttons to the garments.



7. **Double Needle Machine.** This is used in the construction of the different kinds of clothing especially for the inseam, outseam and side seam.



8. **Bartacking Machine.** This is used in reinforcing the opening and closing of pockets



Two Major Parts of the Lockstitch Sewing Machine

The two major parts of the lock stitch sewing machine are the upper and lower parts.

The Upper Parts is composed of:

1. **Head** is the complete sewing machine without a cabinet or stand.
2. **Arm** is the curve part of the head containing mechanism for operating the needle.
3. **Bed** is the flat portion of the machine and beneath is the feed dog where it is mounted, and the shuttle and lower thread are placed.

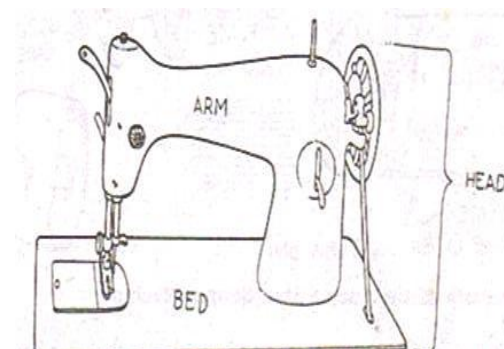

Parts of the Sewing Machine in the Arm

1. **Spool Pin** is the thread holder.
2. **Thread Guide** keeps the thread in position.
3. **Thread Take up Lever** releases the thread and interlocks with the bobbin thread.
4. **Presser bar lifter** moves the presser foot.
5. **Tension** controls the looseness and tightness of stitches.
6. **Needle Bar** holds the needle in place.
7. **Needle Clamp** holds and tightens the needle.
8. **Presser Foot** holds the fabric in place while sewing.
9. **Needle** is a slender tool attached in the needle clamp used for sewing.
10. **Bobbin Winder** controls the bobbin while winding thread.
11. **Stitch regulator** checks the length of the stitches.
12. **Balance Wheel** sets the mechanism in motion.
13. **Belt** connects the balance wheel to the drive wheel.
14. **Stop Motion Screw** hinders moving when loosened and starts

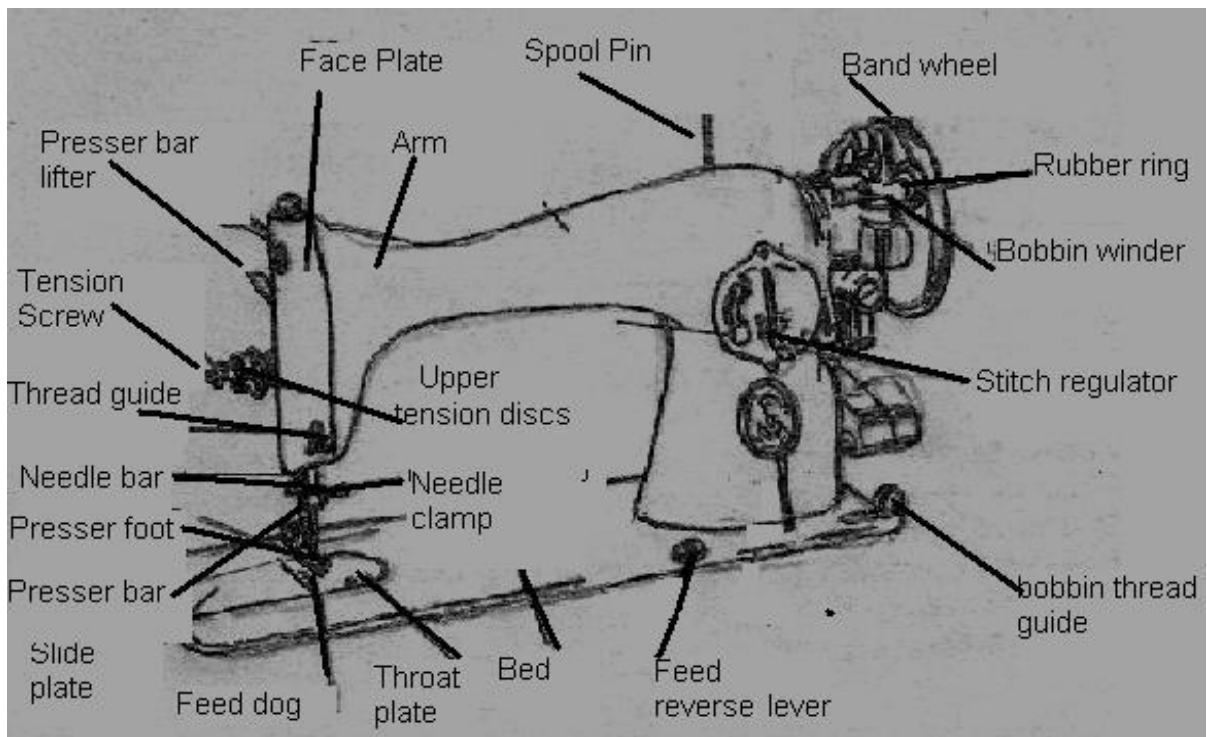

Parts of Sewing Machine under the Bed

1. **Feed Dog** moves the fabric while sewing.
2. **Throat plate** is the windows of the feed dog and it is where the bobbin threads come out.
4. **Slide plate** is a movable plate that covers the shuttle and bobbin case.
4. **Shuttle** holds the bobbin case while sewing.
5. **Bobbin** is a metal spool for winding thread.
6. **Bobbin Case** holds the bobbin.

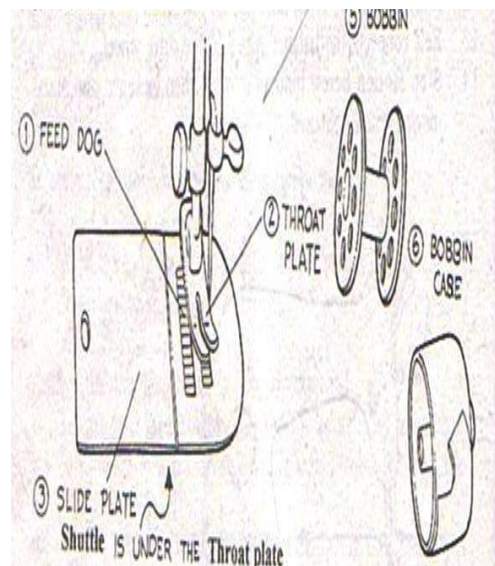

The Lower Parts of the Lock Stitch Sewing Machine

The lower parts of the sewing machine are the cabinet and the stand. The cabinet has drawers and screw on the hinges for the attachment of the head.

The following are the lower parts of the sewing machine and their uses:

1. **Band Wheel** leads the balance wheel through the belt connection.
2. **Band Wheel Crank** moves the band wheel.
3. **Pitman Rod** holds the treadle to band wheel crank.
4. **Belt Guide** holds the belt to its place.
5. **Belt Shifter** removes the belt from the wheel.
6. **Dress Guard** protects the dress from the wheel.
7. **Treadle** is where the feet are stationed to drive the band wheel through the pitman rod.
8. **Legs** support the cabinet of the machine.
9. **Cabinet** holds the head of the machine by interlocking screw on the hinges.

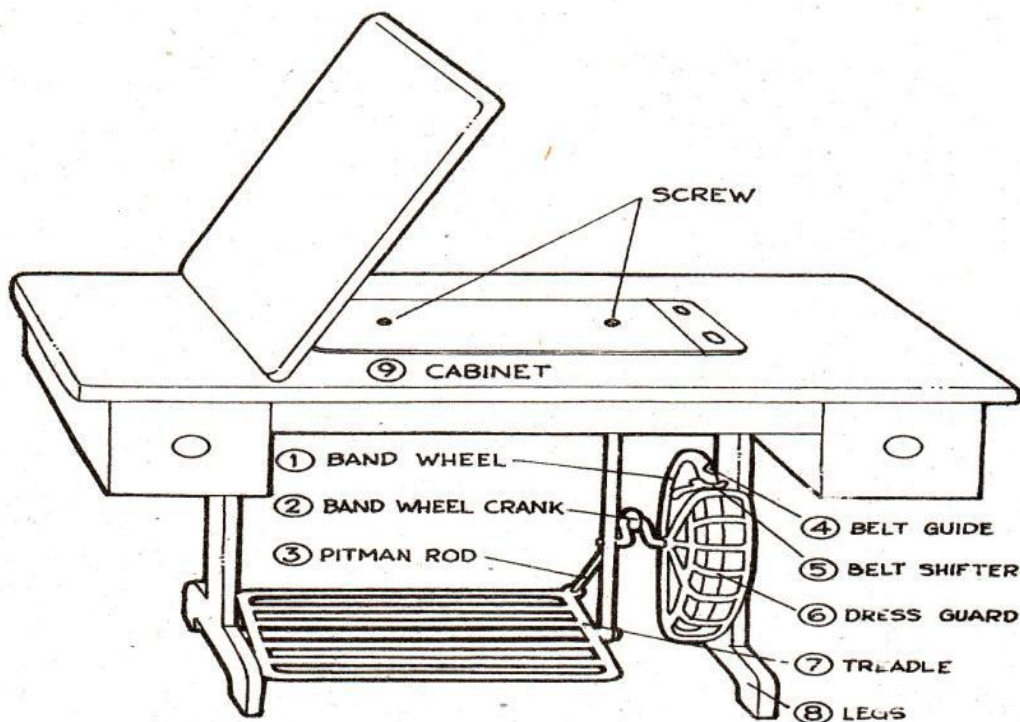



How Much Have You Learned?

Self-Check 1.1

Refer to the Answer Key. What is your score?

Directions: Identify the parts of the lockstitch sewing machine. Write your answer in your quiz notebook.

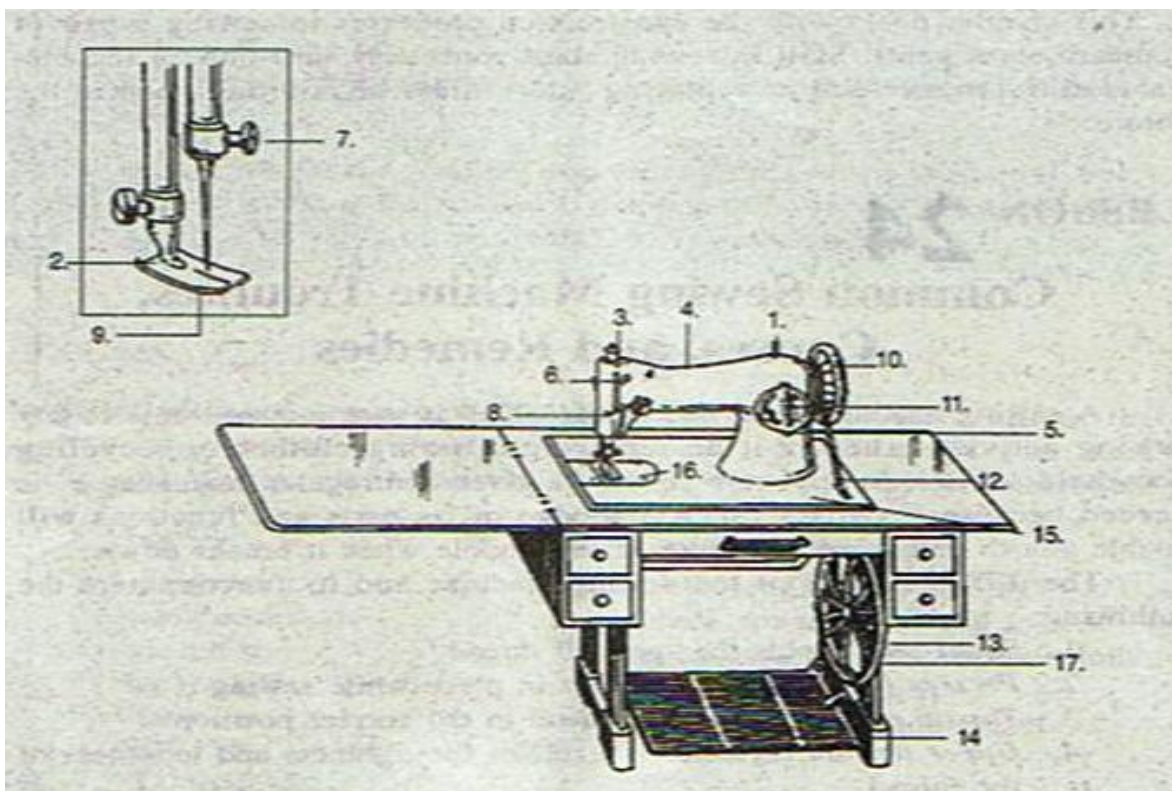



How Do You Apply What You Have Learned?

Show that you learned something by doing this activity

Activity Sheet 1.1

Directions: Draw the following tools in your lecture notebook.

1. Measuring Tools
2. Marking Tools
3. Cutting Tools
4. Drafting Tools
5. Pinning Tools



How Well Did You Perform?

Find out by accomplishing the Scoring Rubric honestly and sincerely. Remember it is your learning at stake!

Points	Criteria
10	All tools were properly drawn and labeled correctly.
8	Almost all of the tools were properly drawn and labeled correctly
6	Some of the items were properly drawn and labeled correctly
4	Most of the items were improperly drawn and labeled incorrectly.

After learning the tools and equipment in sewing, produce a sewing kit with the following:



Create a Sewing Kit

- A. Measuring tools
 - French curve
 - Ruler
 - Tape measure
- B. Cutting Tools
 - Shears
 - Pinking shears
 - Scissors
 - Ripping or thread clip scissors
 - Trimming Scissors
 - Ripper
- C. Marking Tools
 - Tailor Chalk
 - Pencil with eraser
 - Tracing wheel
 - Tracing Paper
 - Thread
 - Pins
- D. Drafting Tools
 - Pattern paper
 - Measuring and shaping tools
- E. Pinning and Sewing Tools
 - Pins
 - Weights
 - Hand Needle
 - Thimble
 - Pin Cushion



How Well Did You Perform?

Find out by accomplishing the Scoring Rubric honestly and sincerely. Remember it is your learning at stake!

Points	Criteria
10	20-22 tools inside the sewing kit.
8	15-19 tools inside the sewing kit.
6	10-14 tools inside the sewing kit.
4	5-9 tools inside the sewing kit.
2	1-4 tools inside the sewing kit.

Objective: Identify and use sewing tools properly.

Materials, Tools and Equipment

Pattern Paper
Measuring tools
Cutting tools

Marking tools
Drafting tools
Pinning and Sewing tools

Task I

Procedure:

Your teacher will choose three (3) of the following tools:

- a. measuring tools
- b. marking tools,
- c. cutting tools
- d .drafting tools
- e. pinning tools

You will be asked to identify the uses and characteristics of each tool and demonstrate how to use them properly.

Your teacher will put a check (/) in the appropriate column if you have clearly identified and used the tools properly.

Sewing Tools	Uses	Characteristics	Tools Used Properly
A. Measuring Tools 1. 2. 3.			
B. Marking Tools 1. 2. 3.			
C. Cutting Tools 1. 2. 3.			
D. Drafting Tools 1. 2. 3.			
E. Pinning Tools 1. 2. 3.			



How Well Did You Perform?

Find out by accomplishing the Scoring Rubric honestly and sincerely. Remember it is your learning at stake!

Points	Criteria
10	All tools were properly identified and used properly.
8	Almost all of the tools were properly identified and used properly
6	Some of the items were properly identified and used properly
4	Most of the items were improperly identified and used.



How Do You Extend Your Learning?



Objective: Obtain sewing materials appropriate for beginners.

Visit 2 or more dress shops near your place. Ask for swatches of fabrics appropriate for beginners like you. Examine, analyze and classify the textures and quality of different fabrics. Make a table of comparison and submit it to your teacher.

Put a check (✓) after each item	Yes	No
1. Did I visit 2 or more dress shops in the place?		
2. Did I list down the different kinds of fabrics they are using?		
3. Did I classify the different fabrics?		
4. Was I able to get swatches of different fabrics for samples?		
5. Did I make the necessary examination on the fabrics, write it down, and submit my report to my teacher?		



Congratulations! You did a great job! Rest and relax a while then move on to the next lesson. Good luck!

REFERENCES

Hilario, Carmelita B for Clothing Technology Made Easy with Lesson Plan. Valenzuela City Philippines. 24K Printing Co., Inc.,2001

Competency- Based Learning Material, 4th Year

Complete Guide to Sewing. [www.sewing](http://www.sewingguide.com) guide.com

LESSON 2

Carry out measurements and calculations



LEARNING OUTCOMES:

At the end of this Lesson you are expected to do the following:

- LO 1. Obtain measurements;**
- LO 2. Perform simple calculations; and**
- LO 3. Estimate appropriate quantities.**



Definition of Terms

Accuracy – the exactness of a measured distance or circumference

Calculation – the process or an act of calculating

Calculator – an electronic device used for speed computation

Conversion – a change of figures like changing from centimeters to inches and vice versa

Cost – the amount paid or charge for something that is acquired

English System – the English system has inches for its basic unit

Grain – the direction of fabric threads

Hemline – the marked line at the bottom of the garment where the hem is turned

IMC – Individual Measurement Chart

Length – the longer or longest dimension of an object to measure

Measurement – a systematic procedure of determining the quantity or extent of the entire measurable dimension

Metric System – a decimal system of physical units based on a unit of length known as the meter (Greek metron, “measure”)

Pattern – a piece of paper usually one-half of the body parts used as a guide in cutting the garments

Width – measurement taken at the shortest dimension of the object to measure

LEARNING OUTCOME 1

Obtain measurements

PERFORMANCE STANDARDS

- Parts of the body are measured
- Appropriate measuring tools are selected for job.
- Reading of measurements is practiced with accuracy.
- Accurate measurements are obtained.



Materials

- **Model**
- **Tape measure**
- **Sewing gauge**
- **Ruler**
- **French curve**



What Do You Already Know?

Let us determine how much you already know about carrying out measurements and calculations. Take this test.

Pretest LO 1

- The foundation of pattern drafting is:
 - Mensuration
 - Measurement
 - Body Parts
 - English System
- This measurement is taken from the left of the figure to the right
 - Horizontal measurement
 - Vertical measurement
 - Circumferential measurement
 - None of the above
- Which of the following is used as a set of standard in measurement
 - Metric System
 - English System
 - Metric and English System
 - Tape Measure
- This kind of measurement is taken around the body
 - Vertical
 - Circumferential
 - Horizontal
 - English system
- A 60" long tape with metal tips, made of a material that will not stretch
 - Yardstick
 - Ruler
 - Tape Measure
 - T-square
- It measures around the torso directly under the bustline
 - Bust to bust
 - Waist
 - Lower bust
 - Bust
- It measures from under the arm. Start at the armpit to the wrist.
 - Armpit
 - Hips
 - Underarm
 - shoulder
- Measure around the shoulder under the armpit.
 - Sleevehole
 - Bust
 - Waist
 - torso
- The _____ measurement is taken from the left of the figure to the right
 - Vertical
 - Horizontal
 - Circumferential
 - Curved
- Circumferential measurement is taken around the body.
 - True
 - false
 - maybe
 - Yes



What Do You Need To Know?

Read the Information Sheet 1.1 very well then find out how much you can remember and how much you learned by doing Self-check 1.1.







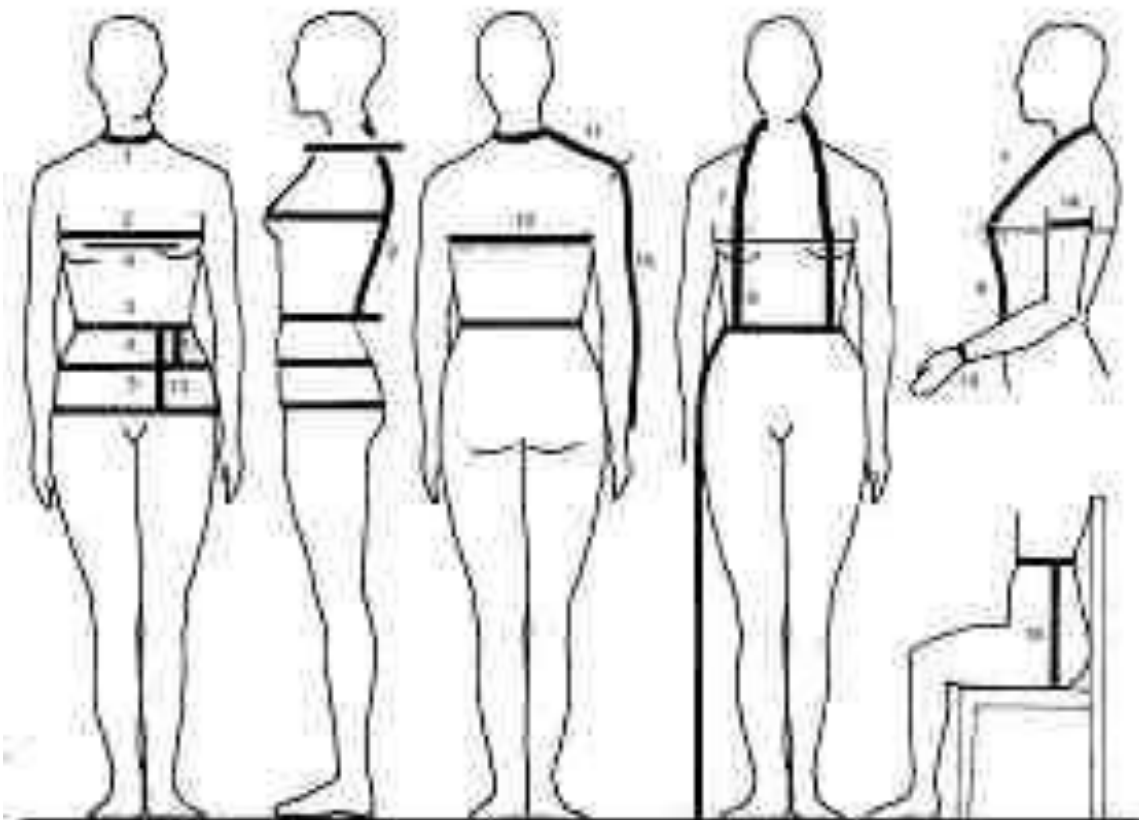

Information Sheet 1.1

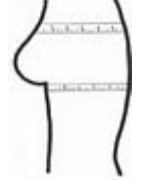

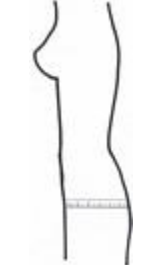





Parts of body to be measured can be taken in:

- Horizontal measurement
- Vertical measurement
- Circumferential measurement

1. The horizontal measurement is taken from the left of the figure to the right.
2. The vertical measurement is taken from the top of the body figure to its base.
3. Circumferential measurement is taken around the body.

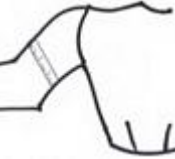
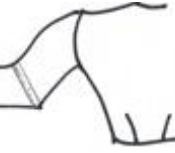
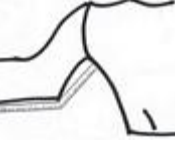

	Neck - Loosely measure around the circumference at the base of your neck.
	Bust - Lift your arms to the side. Measure around your body crossing over the fullest part of your bust. (The tape measure must run directly over your nipples and across your shoulder blades on your back).
	Bust to Bust - Measure from your one nipple to your other nipple.
	Upper Bust - Measure around the torso directly above the bust line. From armhole to armhole +- 8cm down from neck. Lower Bust - Measure around the torso directly under the bustline.
	Waist - Measure around the waist at the narrowest natural waistline point, allowing 2 fingers between your waist and tape measure.
	Hips - Measure around the fullest part of your hips. As a guide, this is often 20cm below your natural waistline. Stand with your knees together.
	Shoulder to Bust - Measure from tip of the shoulder to the centre of bust (nipple).
	Front Shoulder to Waist - Measure from tip of shoulder over bust to natural waistline.
	Shoulder to Shoulder - Measure across the back of neck from socket of one shoulder to socket of the other shoulder.
	Shoulder to Neck - Measure from base of neck along top of shoulder to the shoulder socket.
	Down Center Back - Measure from nape of neck to natural waist.

	Back Shoulder to Waist - Measure from tip of shoulder to natural waist line.
	Across Back - Measure from armhole across back to armhole positioning tape measure + - 8cm down from nape of neck.
	Full Back - Measure from side seam, under armpits to side seam across back, positioning tape measure + - 4cm down under armpit.
	Sleeve Hole - Measure around the shoulder under the armpit.
	Bicep - Measure around the fullest part of the upper arm.
	Elbow - Do a fairly loose measurement around the bent elbow.
	Under Arm - Measure from under the arm. Start at the armpit to the wrist.
	Over Arm - Measure from outer shoulder socket on outside of arm, with a bent arm, to the wrist.
	Side Seam - Measure from under armpit to natural waistline down.
	Upper Arm - Measure from the outer shoulder socket on outside of arm to crook of elbow.

MEN'S APPAREL (Measurement)

A. Vertical Measurement

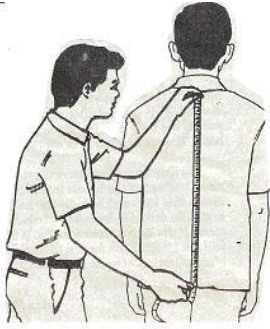

Shirt length - taken from the nape down the center back to the desired length.



Sleeve length - taken from the shoulder tip point down to the desired sleeve length.

Length of pants or shorts – measures along the side below the waist band to the desired length of the pants.

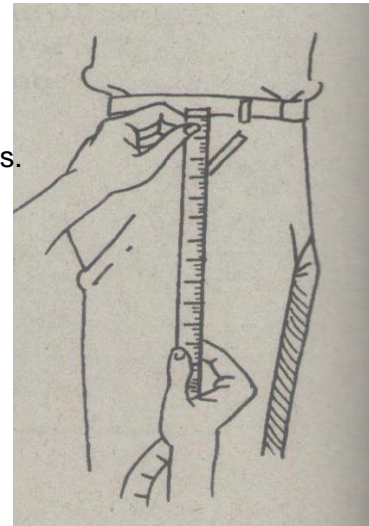

Crotch or Rise – measured by placing a ruler under the crotch then measuring below the waistband down to the top of the level of the ruler.

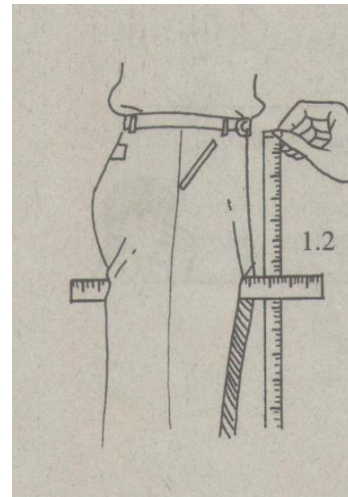

B. Horizontal Measurements



Shoulder - taken from one shoulder point to the other.



Bust/Breast - taken around the body with the tape measure passing over the fullest part of the shoulder blade at the back and over to the apex.

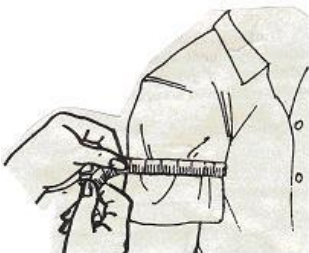

Upper arm girth - taken around the fullest part of the arm in line with the armpit.

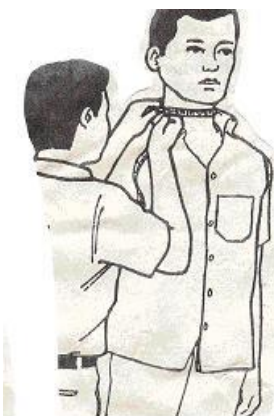

Lower arm girth or sleeve width - taken around the arm two to three inches below the armpit.

Neck measure – taken around the neckline.

Waist (w) - taken around the smallest part of the waistline. Insert two fingers under the tape measure for ease or allowance.

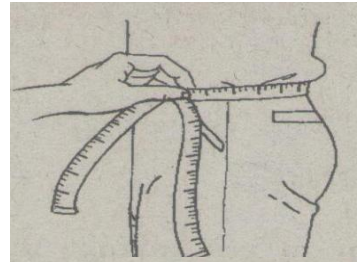

Hip or seat (H) - taken around the fullest part of the hip (buttocks) with two fingers inserted under the tape measure.

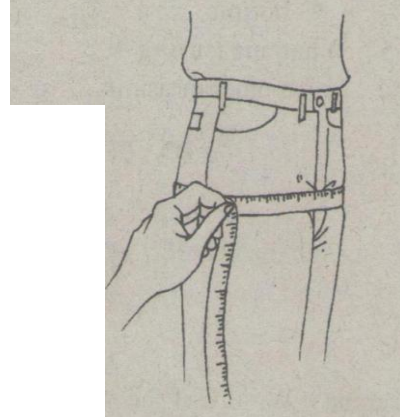

Desired Bottom or Hem Circumference or leg hole – taken around the fullest part of the bottom.



C. Vertical Measurement

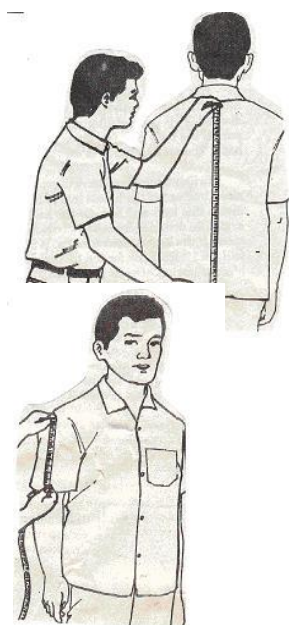

Shirt length - taken from the nape down the center back to the desired length.

Sleeve length - taken from the shoulder tip point down to the desired sleeve length.

Length of pants or shorts–

measured along the side below the waist band to the desired length of the pants.

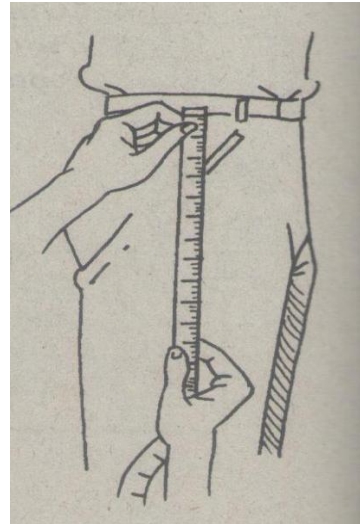

Crotch or Rise – measured by placing a ruler under the crotch then measuring below the waistband down to the top of the level of the ruler.

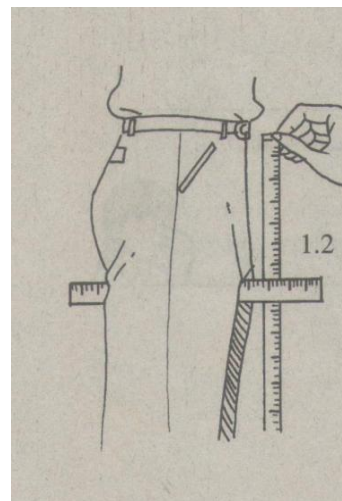

D. Horizontal Measurements



Shoulder - taken from one shoulder point to the other.



Bust/Breast - taken around the body with the tape measure passing over the fullest part of the shoulder blade at the back and over to the apex.

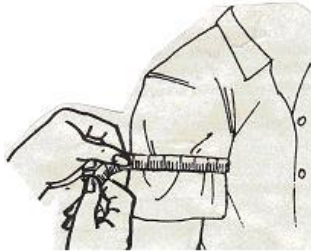

Upper arm girth - taken around the fullest part of the arm in line with the armpit.

Lower arm girth or sleeve width - taken around the arm two to three inches below the armpit.



Neck measure – taken around the neckline.

Waist (w) - taken around the smallest part of the waistline. Insert two fingers under the tape measure for ease or allowance.

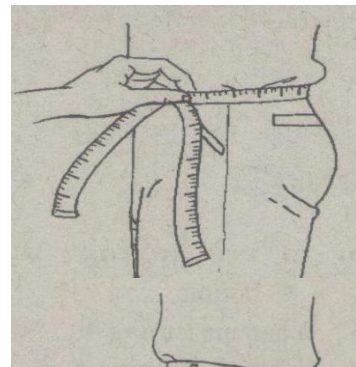

Hip or seat (H) - taken around the fullest part of the hip (buttocks) with two fingers inserted under the tape measure.

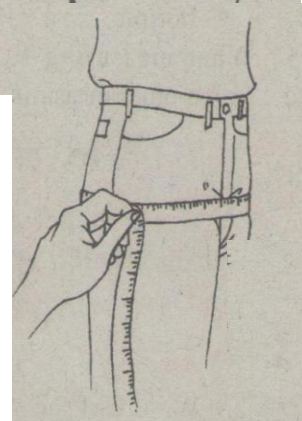

Desired Bottom or Hem Circumference or leg hole – taken around the fullest part of the bottom.





How Much Have You Learned?

Self-Check 1.1

- A. Choose the letter of the correct answer. Write your answers in your quiz Notebook.
- The system where the unit of measurement is centimeter
 - Metric System
 - English System
 - SI Measurement System
 - Decimal System
 - It measures across the back of neck from socket of one shoulder to socket of the other shoulder
 - Shoulder
 - Shoulder to Shoulder
 - Shoulder to Neck
 - Shoulder to Back
 - Measure around your body crossing over the fullest part of your bust.
 - Waist
 - Bust
 - Upper Bust
 - Arm Hole
 - A 60" long tape. One side has inches one is metric with crotch piece or without crotch piece.
 - Tailors Square or L-Square
 - Use Dressmakers Ruler
 - Tape Measure
 - Meter Stick
 - It is used on lapel, pants and skirt contours calibrated on both sides.
 - Tape Measure
 - Aluminum Tailors Curve
 - Tailors Square or L-Square
 - Use Dressmakers Ruler

B. Fill in each blank to complete each statement.

- Shirt length is taken from the nape down the center back to the_____.
- _____ taken around the body with the tape measure passing over the fullest part of the _____ at the back and over to the apex.
- Upper _____ is taken around the fullest part of the arm in line with the armpit.
- _____ is taken around the fullest part of the bottom.
- Hip or _____ taken around the fullest part of the hip (buttocks) with two fingers inserted under the tape measure.

Refer to the Answer Key. What is your score?



How Do You Extend Your Learning?

Objective: Students will be able answer the questions based on their knowledge about obtaining measurements and advanced study in basic calculations in dressmaking.

Instruction: Answer the following questions briefly.

1. Which measuring device is used to take the circumference of the body?

2. What are the types of measurements?

3. What are the tools used in obtaining measurements?

4. How will you convert inches length of fabric into centimeters.

5. What are the four fundamental of operations?



How Do You Apply What You Have Learned?

Show that you learned something by doing this activity

Activity Sheet 1.1

Objective: Students will be able to get their measurement thru a paired activity using English and Metric System

Materials, Tools and Equipment: Measuring Tools

Procedure: Record all your measurements according to the following system.

My Measurements

NAME _____

MEASUREMENT	ENGLISH SYSTEM	METRIC SYSTEM
Bust		
Lower Bust		
Shoulder to Bust		
Front Shoulder to Waist		
Waist		
Shoulder to Shoulder		
Across Back		
Bicep		
Elbow		
Over Arm		
Waist Circumference		
Hip Circumference		
Bottom Circumference		
Crotch		
Length of shorts		

Operation Sheet 1.1

Objective:

At the end of this practice, the learner/trainee should be able to:

1. measure the length and the width of a cloth for table napkin
2. sew simple table napkin

<input type="checkbox"/> Materials
<input type="checkbox"/> • Fabric
<input type="checkbox"/> • Pins
<input type="checkbox"/> • Thread
<input type="checkbox"/>
<input type="checkbox"/> Tools
<input type="checkbox"/> • Tape measure
<input type="checkbox"/> • Scissor
<input type="checkbox"/>
<input type="checkbox"/> Equipment
<input type="checkbox"/> • Sewing machine
<input type="checkbox"/>

Instructions:

Choose the perfect fabric.

I suggest using linen (perfect for a more formal table), cotton, or a blend of the two. Synthetic fibers, like polyester, make ironing easier, but it's very hard to remove stains from poly and poly blends—and napkins will definitely get stains. For more casual napkins, check out your

local quilt shop for some great cotton holiday prints. You can skip the embellishment with a print, but a mitered hem is a great finishing touch on both solid and printed fabric.

Cut accurately.

1. Determine the size of the finished napkins. Measure some you have that seem just right or use the dimensions I used for my cocktail and dinner napkins: The cocktail napkins are 9 inches x 9 inches finished and the generous dinner napkins are 21 inches x 21 inches finished.

2. It's important that you start by finding the exact grain on the fabric. Do this by pulling a thread across the width at one end or square up a line from the selvage. Tearing across the width of cotton fabric will also give the straight grain.

3. Cut a square for each napkin, using the established grainline as a guide, that's 1 inch larger on each edge than the finished napkin size. (For a 9-inch cocktail napkin, cut an 11-inch square). To form the hem, turn in and press 1 inch all around. Then press under 1/4 inch on each edge.



Turn in a 1-inch hem, then turn in the raw edge 1/4 inch.

Miter the corners.

1. Mark the point where the inner folded edges intersect with two pins.



With two pins, mark the point where the hem edges intersect at the inside corner.

2. Open the hem, keeping the 1/4-inch fold in place, and turn right sides together, matching pin marks.

3. Mark a line from the outside corner of the hem to the pins (the inside corner) and pin the two layers together.

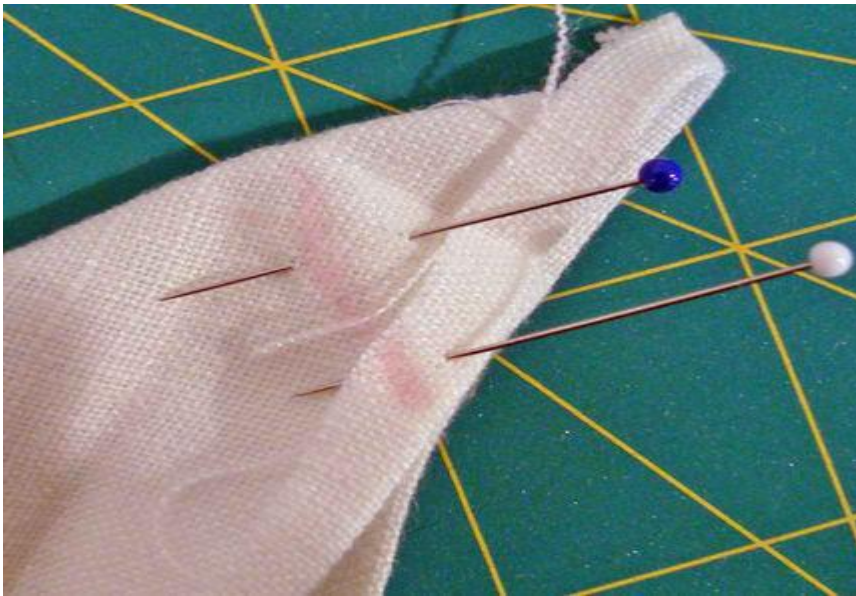

Draw a line from the outside corner to the inside corner (the point where the hem edges intersect).

4. Stitch diagonally along the marked line.



Sew along the line.

5. Turn the corner to the right side to check that the miter fits.



Always check to be sure the miter is just right before trimming away the excess fabric.

6. Turn inside out again, then trim away the excess fabric, making a 1/4-inch seam allowance.



Trim the seam allowance to 1/4 inch.

7. Press this seam open. Turn right side out and press.



Press the seam open. (This is the perfect time to use a point presser and pounding block that I wrote about last week).

8. Sew the hem in place along the inner fold and admire your miter!





How Well Did You Perform?

Find out by accomplishing the Scoring Rubric honestly and sincerely. Remember it is your learning at stake!

	Excellent 5	Very Satisfactory 3	Satisfactory 1	Score
Use appropriate Fabric				
Manipulated Tools and Equipment				
Work Habits				
Finished w/in the time target				
TOTAL				

LEARNING OUTCOME 2

Perform simple calculations

PERFORMANCE STANDARDS

- English and Metric systems of measurement are identified and applied.
- Simple calculations are performed based on the job requirement.
- Reading of measurements is practiced with accuracy.



Materials

- Conversion Chart
- Calculator
- Paper and Pencil



What Do You Already Know?

Let us determine how much you already know about the use farm tools and equipment. Take this test.

Pretest LO 2

- A. Read each question carefully and choose your answer.
1. An electronic device used for speed computation
 - a. Computer
 - b. Calculator
 - c. Cellphone
 - d. Camera
 2. The amount paid or charge for something that is acquired
 - a. Cost
 - b. Computation
 - c. Payment
 - d. Total Cost
 3. A change of figures like changing from centimeters to inches and vice versa
 - a. Calculate
 - b. Converted
 - c. Conversion
 - d. Computation
 4. How many centimeters are there in one inch?
 - a. 1.905 Centimeters
 - b. 2.54 Centimeters
 - c. 3.81 Centimeters
 - d. 5.08 Centimeters
 5. How many yards are there in 4.572 meters?
 - a. 2 Yards
 - b. 3 Yards
 - c. 4 Yards
 - d. 5 Yards
- B. Convert the following:
6. 5 inches = ___ centimeters
 7. 0.25 centimeters = ___ inch
 8. 9 inches = ___centimeters
 9. 0.9144 meters = ___ yards
 10. 5 yards = ___meters



What Do You Need To Know?

Read the Information Sheet 2.1 very well then find out how much you can remember and how much you learned by doing Self-check 2.1.

Information Sheet 2.1

METRIC CONVERSION CHART

Simple calculation is an easy mathematical application used to determine the accurate measurement of body parts, length and width of materials and cost needed to create an apparel.

This is the process in which the four fundamental of operations (MDAS) is involved.

Length and Width of Materials

In measuring the length and width of materials needed such as fabrics, we also need the use of the Metric measurement system.

Metric Conversion Chart for Fabric and Sewing

1/4 Inch	=	0.25 Centimeters
1/2 Inch	=	1.27 Centimeters
5/8 Inch	=	1.59 Centimeters
3/4 Inch	=	1.905 Centimeters
1 Inch	=	2.54 Centimeters
1.5 Inches	=	3.81 Centimeters
2 Inches	=	5.08 Centimeters
2.5 Inches	=	6.35 Centimeters
3 Inches	=	7.62 Centimeters
3.5 Inches	=	8.89 Centimeters
4 Inches	=	10.16 Centimeters
4.5 Inches	=	11.43 Centimeters
5 Inches	=	12.7 Centimeters
5.5 Inches	=	13.97 Centimeters
6 Inches	=	15.24 Centimeters
6.5 Inches	=	16.51 Centimeters
7 Inches	=	17.78 Centimeters
7.5 Inches	=	19.05 Centimeters
8 Inches	=	20.32 Centimeters
8.5 Inches	=	21.59 Centimeters
9 Inches	=	22.86 Centimeters
9.5 Inches	=	24.13 Centimeters
10 Inches	=	25.4 Centimeters
10.5 Inches	=	26.67 Centimeters
11 Inches	=	27.94 Centimeters

11 Inches	=	27.94 Centimeters
12 Inches	=	30.48 Centimeters
1 Yard	=	0.9144 Meters
2 Yards	=	1.8288 Meters
3 Yards	=	2.7432 Meters
4 Yards	=	3.6576 Meters
5 Yards	=	4.572 Meters

Example:

1. How many inches are there in a 100 centimeters width of fabric?
2. How many centimeters are there in a 60 inches length of fabric?

Answer:

- a. Given: 1 inch = 2.54 cm
 Width of fabric = 100 cm
 Equivalent of an inch to cm = 2.54

Calculation: $\frac{100 \text{ cm}}{2.54 \text{ cm}} = \mathbf{39.37 \text{ inches}}$

- b. Given: 1 inch = 2.54 cm
 Length of fabric = 60 inches
 Equivalent of a cm to an inch = 2.54 cm

Calculation:
$$\begin{array}{r} 60 \text{ inches} \\ \times \frac{2.54 \text{ cm}}{1} \\ \hline 152.4 \text{ cm} \end{array}$$

Cost Needed

Example:

You need to buy a 60 inches length of fabric to be used in making a dress to your customer. You have known that the cost of the fabric that you are going to use is P5.00 per centimeter. How much will you need to buy it?

Step I – Convert the 60 inches length of fabric into centimeters.

$$\begin{array}{r} 60 \text{ inches} \\ \times \frac{2.54 \text{ cm}}{1} \\ \hline 152.4 \text{ cm} \end{array}$$

Step II – Multiply the cost per centimeter to the length of fabric converted.

$$\begin{array}{r} 152.4 \text{ cm} \\ \times \text{Php } 5.00 \\ \hline \text{Php } 777.00 \end{array}$$

Sample Computations for fabric, thread, buttons and other supplies in Sewing

QUANTITY	UNIT	DESCRIPTION OF MATERIALS	UNIT COST	TOTAL COST
3	yrds	POLYESTER COTTON (60" WIDTH)	PHP 25.00	PHP 75.00
1	spool	RED THREAD	PHP 15.00	PHP 15.00
6	pcs	PATTERN PAPER	PHP 2.50	PHP 12.50
10	pcs	BUTTONS	PHP 3.00	PHP 30.00
¼	yds	PELLON	PHP 10.00	PHP 5.00
TOTAL				PHP 133.00



How Much Have You Learned?

Self-Check 2.1

Refer to the Answer Key. What is your score?

- A. Directions: Read and understand the question. Write your answer in your quiz notebook.
- How many inches are there in 6.35 centimeters?

 - What are the four fundamentals of operation?

 - How many centimeters are there in 2 inches?

 - The dressmaker needs to buy 100 inches length of fabric that cost Php15.00 per centimeter. Find the total cost of the fabric.

 - An electronic device used for speed computation.

1. Write the measurements of equivalents of the following:

6. 3' = _____ yards

7. 4. 27" = _____ yards

8. 18" = _____ yards

9. 5. 72" = _____ yards

10. 1 ½ meter = _____ inches

Objective: Students will be able answer the questions based on their knowledge about simple calculations in dressmaking.

Instruction: Answer the following questions briefly.

1. How are body measurements taken?

2. Why is accurate body measurement important?

3. What body measurements should be taken in drafting a skirt pattern?



How Do You Apply What You Have Learned?

Show that you learned something by doing this activity

Activity Sheet 1.1

Objective: Students will be able to record Individual Body Measurement
Convert measurements from inches to centimeters

Materials, Tools and Equipment:

- Measuring Tools
- Pencil

Individual Measurement Chart

Name: _____

Date: _____

Body Parts	Actual Body Measure	
	Inches	Centimeters
▫ Bust		
▫ Bust to Bust		
▫ Upper Bust		
▫ Under Bust		
▫ Waist		
▫ Hips		
▫ Shoulder to Bust		
▫ Front Shoulder to Waist		
▫ Shoulder to Shoulder		
▫ Shoulder to Neck		
▫ Down Center Back		
▫ Back Shoulder to Waist		
▫ Across Back		
▫ Full Back		
▫ Sleeve Hole		
▫ Bicep		
▫ Elbow		
▫ Underarm		
▫ Over arm		
▫ Side Seam		
▫ Upper Arm Length		

LEARNING OUTCOME 3

Estimate Appropriate Quantities

PERFORMANCE STANDARDS

- Reading of measurement is practiced with accuracy
- The fundamentals of arithmetic operations are practiced with accuracy
- Cost of project materials are estimated based on current price



Materials

- Calculator
- Reading measurements
- Conversion table



What Do You Already Know?

Let us determine how much you already know about the use farm tools and equipment. Take this test.

Information Sheet 3.1

ESTIMATE APPROPRIATE QUANTITIES

In planning a project, it is important to estimate the quantity of materials to be used and the cost involved. Doing estimates will help you to make the right decisions so that there won't be any effort, money and time wasted.

Estimating of Materials

In estimating you should know the size and the number of product to be made and the size of the cloth if it is 36", 45" or 60" width. For example, an organizer measuring 12" x 30" with three patch pockets of different designs. For one yard of a 45 width cacha cloth you can make two organizers. So for one organizer you can use $\frac{1}{2}$ yard of a cacha cloth. Estimated cost of the cloth is Php60.00.

The table below shows a sample of materials estimated and the cost good for one project.

Quantity	Materials	Unit Price	Total Cost
$\frac{1}{2}$ yard	Cacha (45" width)	60.00	30.00
$\frac{1}{4}$	Manila paper	7.00	2.00
1 spool	Thread (small)	5.00	5.00
			Total Cost = 37.00

The table below shows a sample of materials estimated and the cost good for twelve products to be produced.

Quantity	Materials	Unit Price	Total Cost
12 yards	Cacha (45" width)	60.00	720.00
3 pcs.	Manila paper	7.00	21.00
1 spool	Thread (big)	35.00	35.00
			Total Cost = 776.00



How Much Have You Learned?

Self-Check 3.1

Direction: Use tables in your estimation for the materials and the cost.

1. You will be to make an organizer of the following given prices. You use a cloth that costs Php55. Manila paper, Php7, spool of thread, Php5. Estimate materials and cost. How much will you spent?
2. You and your three friends agreed that you will share to make your organizer as your project to save money. You will buy your materials at the same time. Estimate your materials and cost for the project.

1.

Quantity	Materials	Unit Price	Total Cost
			Total Cost =

2.

Quantity	Materials	Unit Price	Total Cost
			Total Cost =

Refer to the Answer Key. What is your score?



Congratulations! You did a great job! Rest and relax a while then move on to the next lesson. Good luck!

REFERENCES

Navarro, Leticia S. *Homemaking for You and Me (Clothing Construction)*
Quenzon City, Philippines. Abida Publishing House, Inc., 1985

Hilario, Carmelita B., *Clothing Technology Made Easy*, Publisher
National Bookstore Printed 24k Printing Corp., Valenzuela City

www.singermachines.co.uk/dress-form-inform

LESSON 3

Create design for a simple project



LEARNING OUTCOMES:

At the end of this Lesson you are expected to do the following:

- LO 1. Sketch simple project design; and
- LO 2. Produce simple project;



Definition of Terms

Asymmetrical - having no balance or symmetry.

Balance - a state of equilibrium or parity characterized by cancellation of all forces by

Cacha - a kind of cotton cloth good for beginner sewer for project making.

Colorfast – do not fade easily

Design – a blueprint

Emphasis - a special attention or effort directed toward something.

equal opposing forces.

Harmony - means a relationship of different portion of a design

Hue – the family group name of a color

Intensity – means the brightness or dullness of a color

Primary Colors – the sources of all colors

Proportion - part considered in relation to the whole.

Proportion – is the pleasing relationship of all parts of the object with one another.

Rhythm – these are smooth movement repeated again and again

Secondary Colors – are produced when mixing two equal amount of primary colors

sides of a dividing line or plane or about a center or an axis.

Symmetry - exact correspondence of form and constituent configuration on opposite

LEARNING OUTCOME 1

Sketch simple project design

PERFORMANCE STANDARDS

- Design for a simple project is sketched applying the principles of design and applying the color harmonies



Materials

- Pictures
- Catalogue
- Different kind of designs



What Do You Already Know?

Let us determine how much you already know about the sketching simple project design. Take this test.

Pretest LO 1

Direction: Choose your answer in the box. Write your answer in your notebook.

proportion	emphasis	formal balance	informal balance	rhythm
harmony				
balance	gradation	repetition	radiation	

A.

1. It is the pleasing relationship of all parts of the object with one another.
2. It can be described as having equal "weight" on equal sides of a centrally placed like a see saw.
3. When the structure decoration and accessories are different both sides from the centre of the design.
4. It refers to the relative size and scale of the various elements in a design. The issue is the relationship between objects, or parts, of a whole.
5. This is an easy way of balancing but such balance lends monotony to the dress.
6. It is the center of interest.
7. These are smooth movement repeated again and again.
8. A kind of rhythm can also be created by the use of radiated lines.
9. It means a relationship of different portion of a design.
10. Eyes can move easily from one part to the other on the small lines created by gathers.

B. Identify the following;

1. Primary colors are blue, yellow and _____.
2. Yellow mix with red is _____.
3. Red mix with violet is _____.
4. Tint or red is _____.
5. Maroon is _____ of red.
6. Analogous or adjacent color of green is _____ and _____.
7. Complement of orange is _____.
8. Split complement of red is _____ and _____.
9. Triad of violet is _____ and _____.
10. Neutral colors are _____, _____ and _____.



What Do You Need To Know?

Read the Information Sheet 1.1 very well then find out how much you can remember and how much you learned by doing Self-check 1.1.

Information Sheet 1.1

PRINCIPLES OF DESIGN

The principles of designs are concepts used to organize or arrange the structural elements of design. These the ways in which these principles are applied the affects the expressive content, or the message of the work.

Principles

Balance - According to this principle, from the centered of the dress, design should be identified on both sides may be achieved ways:

a. **Symmetrically or the formal balance** - can be described as having equal "weight" on equal sides of a centrally placed like a see saw. This is an easy way of balancing but such balance lends monotony to the design.



b. **Asymmetrically or the informal balance** – When The structure decoration and accessories are different both sides from the center of the design. In this design attraction both sides is created by using different accessories.

c. **Proportion** - is the pleasing relationship of all parts of the object with one another. Proportion refers to the relative size and scale of the various elements in a design. The issue is the relationship between objects, or parts, of a whole.

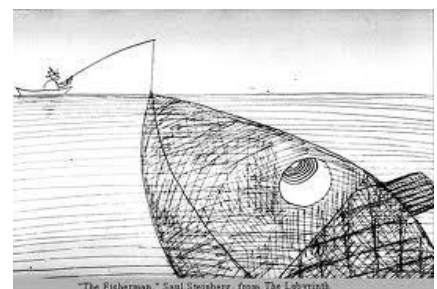



Emphasis – every pleasing design has one part that is more interesting than any other. This is the emphasis or the center of interest.



Rhythm – these are smooth movement repeated again and again. Rhythm is an important principle of art. It is created by repeated use of the design. If there is rhythm in a design, the eye would move easily from one part to the other.

Rhythm can be created in three ways in a design:

- a. *Repetition* of lines, colors, or accessories. Parallel lines are formed by the use of seams, buttons, embroidery, lace, etc. which helps uninterrupted eye movement.



Radiation. Rhythm can also be created by the

radiated lines. These lines are created by gathers. Eyes can move easily from one part to the other on the small lines created by gathers. Such lines can be seen in gathers on neckline, arm and skirt.

Gradation. Rhythm can be created by gradual change of lines, shape or shade of the color.



Harmony - means a relationship of different portion of a design. Harmony should be achieved through judicious use of color, shape, and texture to give a feeling of oneness.





How Much Have You Learned?

Self-Check 1.1

Identification: Write your answer on the space provided for.

- _____ 1. A pants with a pocket on both sides with the same style, size and shape.
- _____ 2. A large hat on a small boy is out of proportion to his size.
- _____ 3. It may be a pretty collar, an attractive bow or a lovely pin.
- _____ 4. A kind of rhythm can be created by gradual change of lines, shape or shade of the color.
- _____ 5. It is a relationship of different portion of a dress.

Refer to the Answer Key. What is your score?

Read the Information Sheet 1.2 very well then find out how much you can remember and how much you learned by doing Self-check 1.2.

Information Sheet 1.2

COLOR THEORY

The first thing you usually notice about clothes or anything is their color. Before you start studying which colors look best together, you should learn the meaning of color terms and the rules that apply to colors.

The Color Wheel



photobucket.com/images/color%20wheel/

Primary Colors – the sources of all colors, even though there are thousands and thousands of colors in the world, they are all made up of these colors – **red, blue and yellow**.

Secondary Colors – are produced when mixing two equal amount of primary colors. If you mix equal amount of yellow and blue you will have green, equal parts of red and blue will have violet, and red and yellow you will have orange.

Look at the color wheel you will find these colors – **orange, green and violet**.

Intermediate Colors – are produced by mixing two equal amount of primary and secondary colors. Example, if you mix equal parts of yellow (primary color) and green (secondary color) you will have **yellow-green**. Noticed that yellow-green is found between yellow and green on the color wheel.

The intermediate colors are;

Yellow + green = *yellow-green*

Blue + green = *blue-green*

Blue + violet = *blue-violet*

Red + violet = *red-violet*

Red + orange = *red-orange*

Blue + orange = *blue-orange*

Pure Colors – are the primary, secondary and intermediate colors because they have no white, black and gray in them. Pure colors are also called “normal, true and basic colors”.

Tints – when pure colors are mixed with white, they are made lighter. Example, when white is added to red you have pink. In other words pink is a tint of red. The more white you add, the lighter the pink will be. Tints are also called “pastels”.

Shades – when pure colors are mixed with black, they are made darker. Example, when black is added to red you have maroon, a shade of red. The more black you add, the more darker you have.

Grayed colors – most colors we used in clothes are grayed colors rather than bright, pure colors you see on the color wheel. Grayed colors are also referred to as “soft colors” or “dull colors”. The more gray you add, the more duller the color will be.

Neutrals – are white, black and gray. They look well with another and with all other colors. The more grayed colors becomes, the more different colors it will harmonize with.

Warm and Cool Colors

Cool colors – are green, blue-green, blue, blue-violet, violet. Blue is the coolest color. They are adjacent to one another in the color wheel.

Warm colors – are red, red-orange, orange, yellow-orange, and orange. Red is the warmest color. They are also adjacent in the color wheel.

Qualities of Colors

Hue – is the family group name of a color. It is the name of a color. Ones they are combined differently and given new names.

Value – refers to the lightness or the tint or the darkness of the shade. The scale of the value colors are from the very lightest tint to the very darkest of the shade.

Intensity – means the brightness or dullness of a color. When you refer to a color as “bright” or “very bright” or “dull” or “very dull” you are describing its intensity. Example, green peppers are bright yellow-green, while olives are dull yellow green.

Color Schemes

The beauty of any color scheme depends upon how well the colors harmonize. To harmonize, colors must appear to belong together.

1. One-color harmony (monochromatic color) – the easiest color scheme to follow is one that uses the same color in different values and intensity. Example, **dark blue suit with very dark blue accessories and a light blue blouse.**



2. Adjacent color harmony – or analogous color harmony. Since they are near each other on the color wheel, neighbor color harmony. Example, **yellow-orange, orange, and yellow green** are next to each other on the color wheel; therefore, a pleasing adjacent color harmony may be made from them.



3. Complementary Color Harmony – these are colors that are opposite in the color wheel. Using these colors may be very pleasing.
 - a. Complementary colors – directly opposite in the color wheel. Example, **red and green, blue and orange, yellow and violet.**

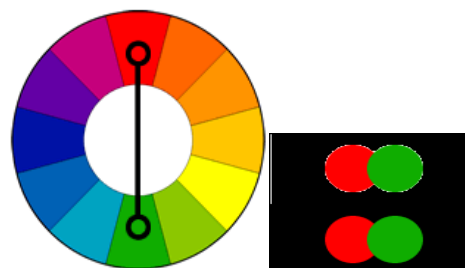

- b. Split complementary colors – a variation of the complementary color scheme. In addition to the base color, it uses the two colors adjacent to its complement.

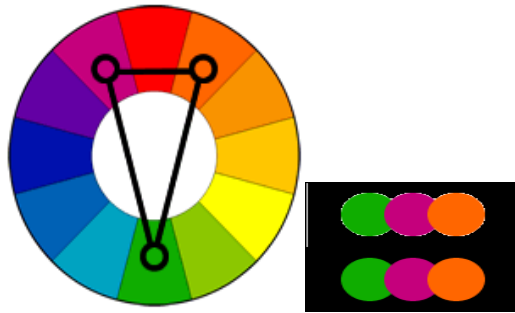

www.tigercolor.com/color-lab/color-theory/color-harmonies.htm

- c. **Triad** - A triadic color scheme uses colors that are evenly spaced around the color wheel. Triadic color harmonies tend to be quite vibrant, even if you use pale or unsaturated versions of your hues.

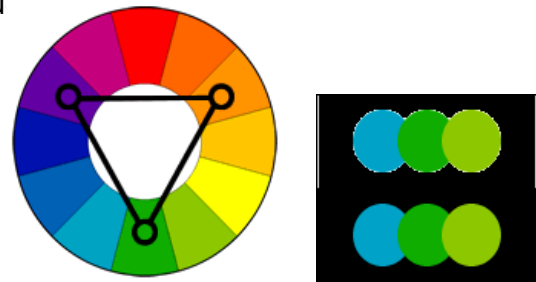

How Much Have You Learned?

Self-Check 1.2

Refer to the Answer Key. What is your score?

Identify the following;

1. Primary colors are red, yellow and _____.
2. _____ is a color formed by mixing yellow and blue.
3. When red is mix with orange, the color is _____.
4. Tint of red is _____.
5. Maroon is _____ of red.
6. Analogous or adjacent color of blue is _____ and _____.
7. Complement of red is _____.
8. Split complement of yellow is _____ and _____.
9. Triad of orange is _____ and _____.
10. Neutral colors are _____, _____ and _____.



How Do You Extend Your Learning?

Instruction: Copy this design in a bond paper and apply the principles. Color the picture and apply the color harmonies. This will be your project.

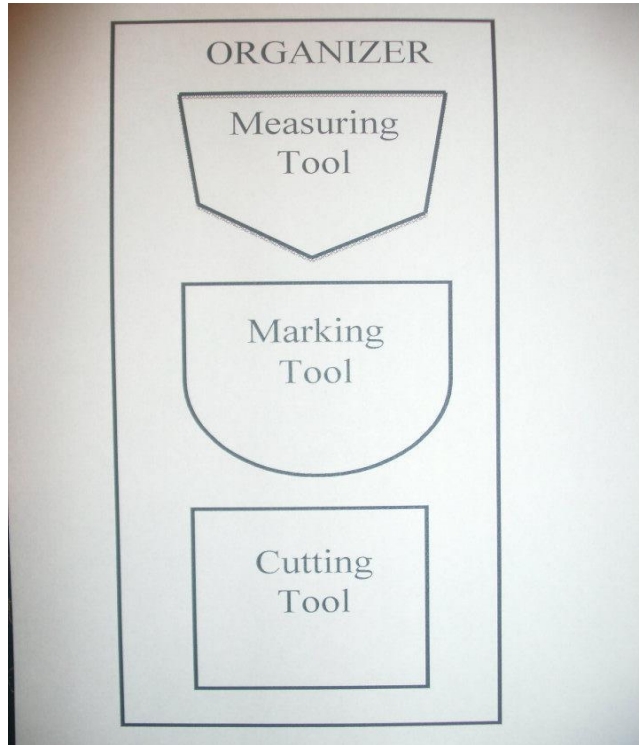

LEARNING OUTCOME 2

Produce simple project

PERFORMANCE STANDARDS

- Project produced in accordance to the specifications of designs



Materials

Sewing Tools

- Needle
- Plain cloth (any color)
- Thread (any color)



What Do You Already Know?

Let us determine how much you already know about the use farm tools and equipment. Take this test.

Pretest LO 2

Direction: Identify the different pictures



1. _____

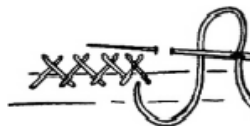

5. _____



2. _____

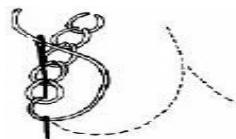

6. _____

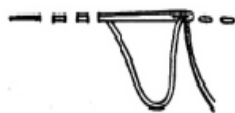

3. _____



7. _____

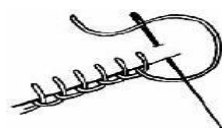

4. _____

B. Arrange the steps in assembling the organizer by numbering.

- _____ Remove hanging threads.
- _____ Zigzag raw edges of the pockets.
- _____ Fold and baste of the organizer before sewing in the sewing machine.
- _____ Press.
- _____ Lay the pockets, pin, baste then machine stitch.
- _____ Put labels for each pockets as marking tools, measuring tools and cutting tools.
- _____ Sew the handles for hanging.
- _____ Work on the pockets by putting designs applying the principles of designs.



What Do You Need To Know?

Read the Information Sheet 2.1 very well then find out how much you can remember and how much you learned by doing Self-check 2.1.

Information Sheet 2.1

BASIC HAND STITCHES

Sewing the basic hand stitches are very easy if you learn each step thoroughly before you start practicing the next step. Sewing by hand is a skill that most, if not all, people should probably attempt to master at some point.

	<p>Back Stitch Make one running stitch, then take a back stitch to the beginning of the first stitch, thus overlapping each running stitch. Resembles machine stitching and is used to strengthen a seam made by hand.</p>
	<p>Basting Basting is quite important in successful sewing. This is used to hold fabric temporarily in place, until permanently stitched. There are four types of basting; hand basting, machine basting, pin basting and basting edges with an iron.</p>
	<p>Running Stitch To make this stitch, push point of needle in and out of fabric until you have several stitches on the needle. Hold fabric taut with left hand, pull the needle through. Practice until you make fine even stitches.</p>
	<p>Outline Stitch This stitch is similar to the back stitch but it is slanted. Make one slanted backstitch in front of another letting each one overlap the one before it just a little bit, until the design is filled.</p>
	<p>Blanket Stitch Put your needle in 1/4 inch from the edge of the fabric, put the thread under the point of the needle and pull through.</p>
	<p>Catch Stitch This is used for a flat finish next to fabric, such as seam binding on a hem. Hold open hem edge away from you, work from left to right, Take a stitch in the hem, then a tiny stitch to the right just beyond edge of hem with the point of needle to the left. This makes diagonal lined that cross each other.</p>
	<p>Chain Stitch Insert the needle in and out of the fabric (as in the running stitch). Bring the thread under the tip of the needle while still in the fabric, then pull the needle through.</p>



How Much Have You Learned?

Self-Check 2.1

A. Identify the following basic hand stitches. Write your answer before the number.

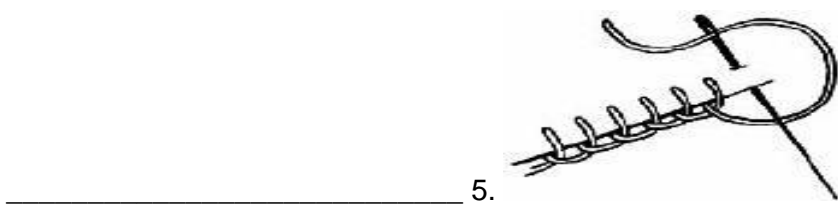
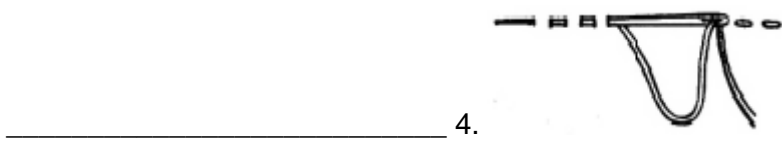
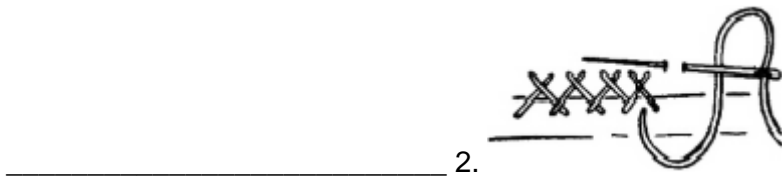
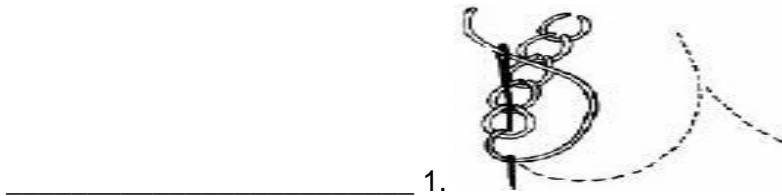

6 – 9 What are the four types of basting stitch?

10. _____ stitch is similar to the backstitch but it is slanted.



How Do You Extend Your Learning?

Make a sample of the different basic hand stitches in a 3" x 3" plain cloth and compile them in a short bond paper. Label them and write their descriptions.



How Do You Apply What You Have Learned?

Show that you learned something by doing this activity

job Sheet 2.1

LO2	:	PRODUCE SIMPLE PROJECT
Objective	:	Demonstration how to make an organizer for sewing tool
Materials, Tools and Equipment	:	½ yard cloth, 1 spool of thread (small), manila paper, shears, pins, needles, tailor's chalk, pencil, ruler and sewing machine

Procedure

1. Make a sketch of your organizer using a measurement of 12" x 30" as the size, or you can copy the sample as illustrated above.
2. Make patterns for the main part which is the base of the organizer using a manila paper. 12" x 30" in size.
3. Make patterns for the patch pockets 8" x 8" as the size with three designs, plain, oval and pointed.
4. Lay your pattern on the cloth. Lay large pattern first then the smaller patterns
5. Pin the patterns.
6. Mark the cloth
7. Mark sewing allowances
8. Cut the cloth. Reminder: before cutting measure twice or more if there is doubt of the measurements.
9. Construction or assembling process by unit method.
 - a. Work on the pockets by putting designs applying the principles of designs using the different basic hand stitches and applying the theories of colors.
 - b. Put labels for each pockets as marking tools, measuring tools and cutting tools. This will be the emphasis of the organizer.

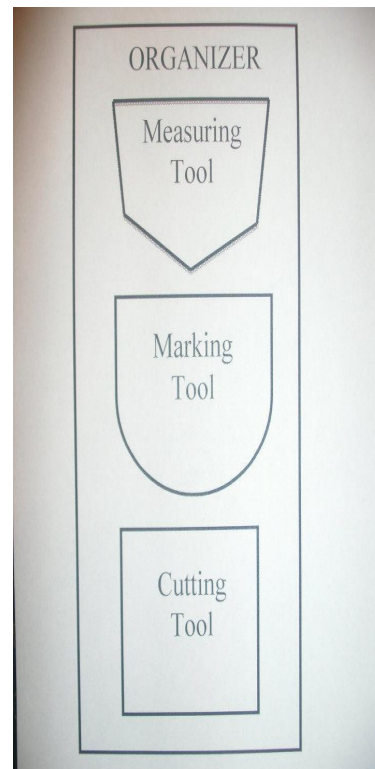

- c. Zigzag raw edges of the pockets to make it durable and edges will not ravel.
- d. Sew the handles for hanging.
- e. Work on the base as the main part of the organizer by folding the sides. Baste folds before sewing in the sewing machine.
- f. Lay the pockets, pin, baste then machine stitch.
- g. Remove hanging threads.
- h. Press.



How Well Did You Perform?

Find out by accomplishing the Scoring Rubric honestly and sincerely. Remember it is your learning at stake!

Rubric in Drafting the Pattern for the Organizer

Item	3	2	1	Score	Weighted Score
Tools (10%)	Tools were complete, appropriate and correctly used.	Lack of one tool, some are appropriate and correctly used.	Lack of two or more tools, some are appropriate and not correctly used.		
Procedure (60%)	Used the correct method. Procedures correctly followed.	Used the correct method. Procedures incorrectly followed.	Failed to use the correct method. Procedures not followed.		
Pattern (20%)	All pattern details were correctly measured and accurately drafted.	Some pattern details were inaccurately drafted.	All pattern details are not drafted correctly and accurately.		
Speed (10%)	Finished the pattern ahead of time.	Finished the pattern on time.	Finished the pattern more than the allotted time.		
Total					

Legend:

Weighted Score: = Score x Item (weight)

Score Percentage = $\frac{\text{Total weighted score}}{\text{Perfect score (3)}} \times 100$

Example:

3 x 10% = .3

2 x 60% = 1.2

2 x 20% = .4

$$3 \times 10\% = .3$$

$$\text{Total weighted score} = \frac{\quad}{\quad} = 2.2$$

Score Percentage

$$= \frac{2.2}{3} \times 50 + 50$$

Grade = 87

Rubric in Constructing the Organizer

Item	3	2	1	Score	Weighted Score
Threads (10%)	Correct shade of thread matches the color of the fabric.	Correct kind, and color but does not match the shade of the fabric.	Incorrect and does not match the color of the fabric.		
Machine stitching (70%)	Stitches are even and proper length followed the sewing line.	Some stitches are crooked, did not follow the sewing line.	Uneven stitches, crooked and did not follow the sewing lines		
Speed (20%)	Finished the organizer ahead of time.	Finished the organizer on time.	Finished the organizer more than the allotted time.		
Total					

Example:

$$3 \times 10\% = .3$$

$$2 \times 70\% = 1.4$$

$$2 \times 20\% = .4$$

$$\text{Total weighted score} = \frac{\quad}{\quad} = 2.1$$

Score Percentage

$$= \frac{2.1}{3} \times 50 + 50$$

Grade = 85

Note: If you want to consider a higher grade of your students adjust score percentage, you can change it to 40 + 60.

Self-Check 2.2

Refer to the Answer Key. What is your score?

Arrange the steps in sewing the organizer for sewing tools by putting the number in their proper order. Write your answer on the space provided before the number.

- _____ Remove hanging threads.
- _____ Zigzag raw edges of the pockets.
- _____ Fold and baste of the organizer before sewing in the sewing machine.
- _____ Press.
- _____ Lay the pockets, pin, baste then machine stitch.
- _____ Put labels for each pockets as marking tools, measuring tools and cutting tools.
- _____ Sew the handles for hanging.
- _____ Work on the pockets by putting designs applying the principles of designs.

Show that you learned something by doing this activity

Job Sheet 2.2

Objective: Sew an apron with creative patch pocket.



Materials, Tools and Equipment:

1 yard of fabric

Piece of coordinating fabric for the pocket

7/8" ribbon

Apron Pattern

Instructions:

1. Place the apron pattern on the folded fabric and cut out.

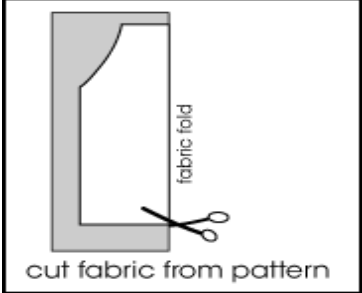

2. Fold the rectangle of coordinating fabric in half with right sides together. Stitch around three sides of the pocket using a 1/2" seam allowance, leaving a 3" opening at the bottom. Clip the corners.
(Pattern for patch pocket may vary depending on the design).

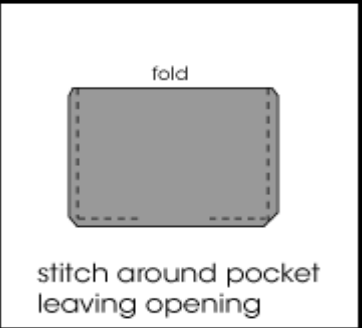

3. Turn the pocket right side out and push out the corners of the pocket with an item like a chopstick. (Don't use something too sharp or you will poke a hole through the fabric.) Press the pocket flat, folding in the raw edges of the opening. Topstitch along the fold, which will be the top of your pocket.

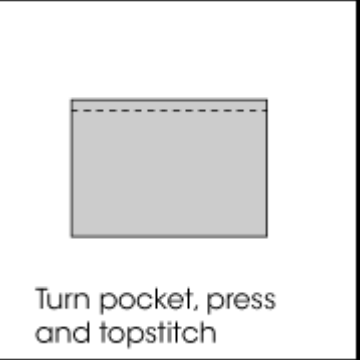

4. Place the pocket on the center of the apron approximately 12" from the top. Stitch the sides and bottom of the pocket to the apron.
(Placement of the pocket may vary).

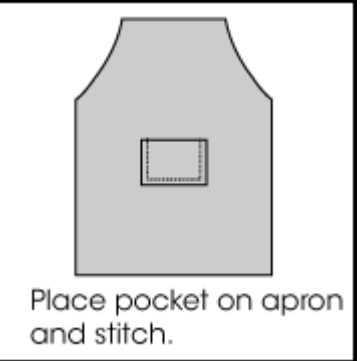

5. Using a double fold hem (folding fabric in 1/2", pressing, then folding 1/2" again and pressing for a 1" hem), pin and stitch the sides and bottom of the apron.

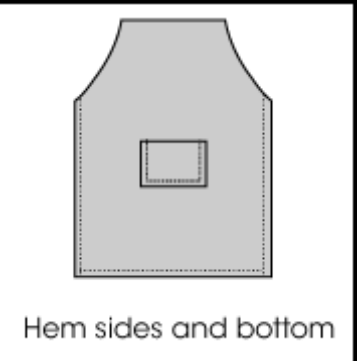

6. Using a double fold hem (folding fabric in $\frac{5}{16}$ ", pressing, then folding $\frac{5}{16}$ " again and pressing for a $\frac{5}{8}$ " hem), pin and stitch the curved side of the apron.

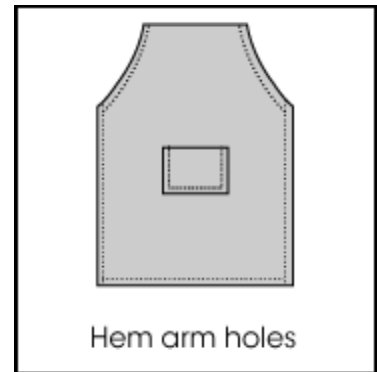

7. Fold down $\frac{1}{4}$ " along top and press. Fold 1" again and press. Stitch facing down.

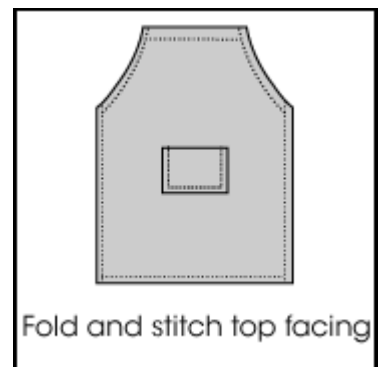

8. Stitch 28" piece of ribbon to top left of apron. Finish raw edge of ribbon by folding over twice and stitching.

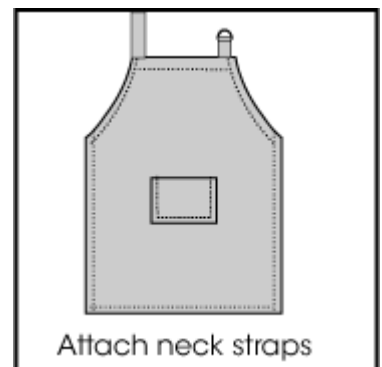

9. Stitch 24" long piece of ribbon at the top of the straight side. Repeat for the other side. Finish raw edge of ribbon by folding over twice and stitching.

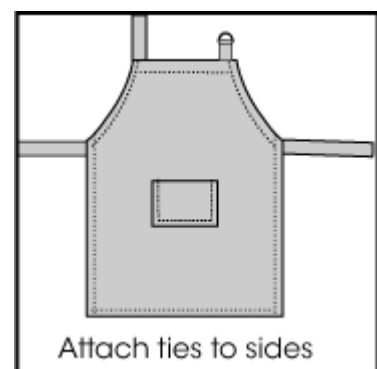



How Well Did You Perform?

Find out by accomplishing the Scoring Rubric honestly and sincerely. Remember it is your learning at stake!

ITEMS	Outstanding (10)	Very Good (7)	Good (5)	Score
A. Construction Process	All steps were followed in the correct sequence	Most of the steps were followed correctly.	Some of the steps were followed correctly	
B. Manipulated Tools and equipment properly	Most of the time	Sometimes	Not at all	
C. Work Habits: Organized, clean and systematic	Most of the time	Sometimes	Not at all	
D. Work within the time target	Finished ahead of time	Finished just in time	Late by 1 day	



Congratulations! You did a great job! Rest and relax a while then move on to the next lesson. Good luck!

REFERENCES

LO1

- Author, copyright year, title, place of publication: publishing house

LO 2

- How You Look and Dress by Byrta Carson
- www.karensvariety.com/ARTICLES/Sewing/BasicHandStitches.htm
- photobucket.com/images/color%20wheel/
- www.preservearticles.com

LESSON 4

Perform Basic Maintenance

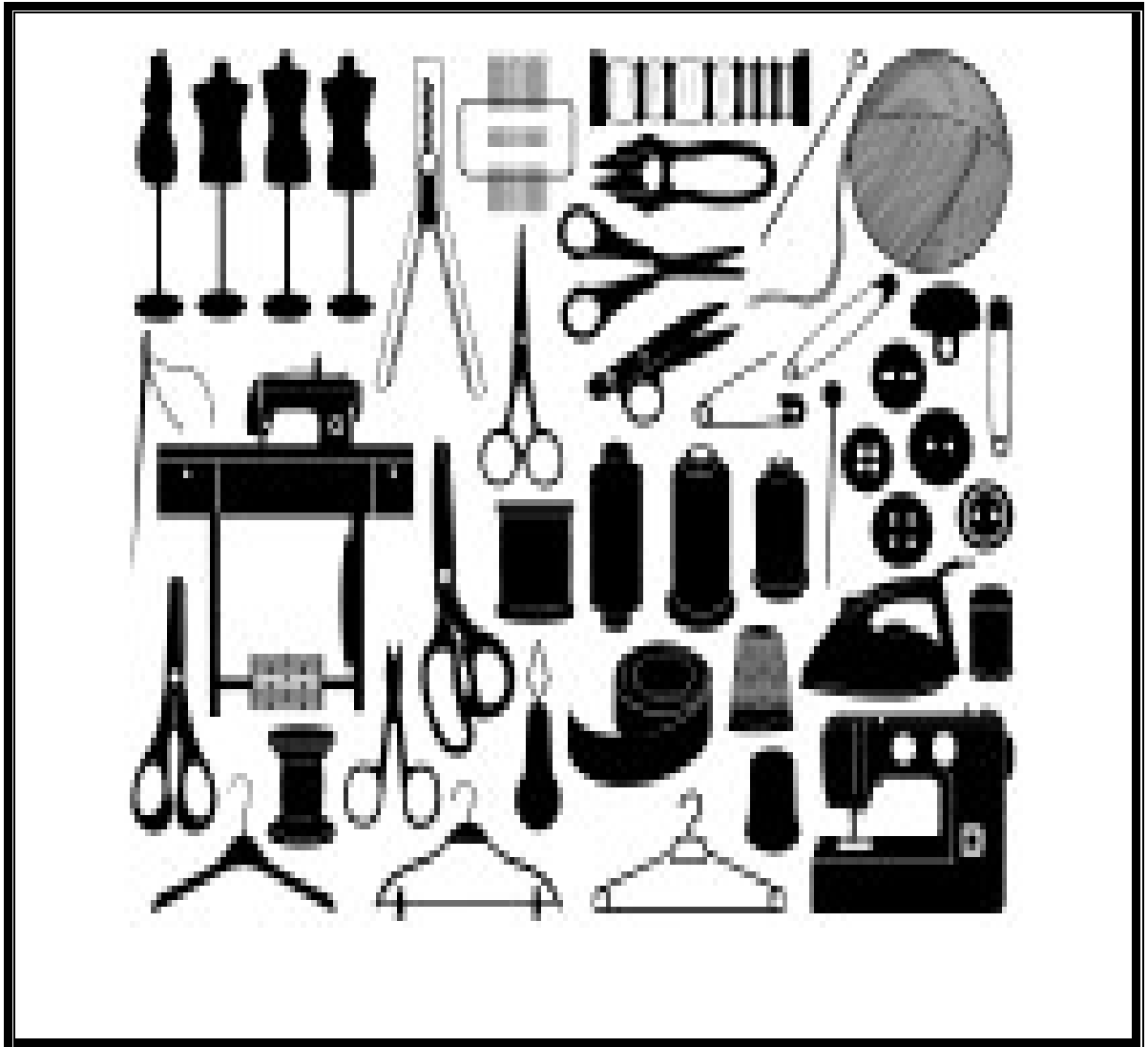

LEARNING OUTCOMES:

At the end of this Lesson you are expected to do the following:

- LO 1. Operate machine and assess its performance;
- LO 2. Clean and lubricate machine; and



Definition of Terms

Absorbent – a material property that sucks-up or takes in the manner of sponge.

Adjust – change present setting as in adjusting tensions.

Balance wheel – the wheel at the right of the arm that sets the mechanism in motion.

Band wheel – the wheel below the upper mechanism that leads the balance wheel through the belt connection

Band wheel crank – moves the band wheel.

Bent – a change of shape or angle caused by pulling or pricking to a harder part such as machine needle driven out of throat plate slot.

Blunt – refers to an unsharp or dull needlepoint that is irreplaceable.

Damp cloth – a cloth applied with moisture on water.

Entangle – forming knots like thread entangled in the bobbin case.

Feed dog – the toothed part mounted on the throat plate that helps move the fabric against the presser foot.

Fault – something is wrong with the machine, system, design etc, which prevents it from working properly.

Gummy – a thick of sticky quality such as oiled accumulated dust on sewing machine part.

Jam – to cause a machine to stuck fast so that it cannot work.

Lift – moving upward as in a presser foot lifter.

Lubricant – a material capable of reducing friction when applied between moving parts.

Lubricate – the act of applying a lubricating agent between moving parts to reduce friction and preventing the form of rust.

Manipulation – the act of managing or operating manually or mechanically a given tool or equipment.

Posture - the correct working body position for a given task.

Pucker – wrinkling of fabric caused by very tight stitches.

Replace – putting something new in the place of an old or damaged part.

Rewind – winding again or repeat winding.

Stitch length – the length of each individual stitch.

Stitch regulator – the part of a sewing machine that controls the stroke of the feed dog and regulates the length of stitches.

Treadle – this is where the feet rest to drive the band wheel through the pitman rod.

Tension – the force that is applied by the machine on your thread.

Trend – a general tendency in the way a situation is changing or developing.

Vital – extremely important and necessary for something to succeed or exist.

LEARNING OUTCOME 1

Operate Machine and Assess Its Performance

PERFORMANCE STANDARDS

- Proper handling of machine is observed.
- Correct procedures in machine operation are identified.
- Common machine troubles are resolved.



Materials

Set of sewing machines



What Do You Already Know?

Let us determine how much you already know about the use farm tools and equipment. Take this test.

Pretest LO 1

Directions: Read and analyze each item carefully and choose the letter of the best answer from the options below. Write your answers in your quiz notebook

1. The upper part of the sewing machine head being driven by hand when starting the machine
 - a. balance sheet
 - b. band wheel
 - c. stop motion screw
 - d. treadle
2. The control of sewing machine lies on the:
 - a. balance sheet
 - b. band wheel
 - c. belt
 - d. treadle
3. The part of the sewing machine that controls the looseness and tightness of stitches is:
 - a. bobbin
 - b. presser foot
 - c. thread guide
 - d. upper tension
4. A machine problem when there is incorrect size of needle or thread is:
 - a. fabric jams
 - b. needle break
 - c. seam pucker
 - d. skipped stitches
5. The part of the sewing machine that controls the stroke of the fee dog is:
 - a. face plate
 - b. feed dog
 - c. slide pucker
 - d. stitch regulator
6. The oil that lubricates and gives the machine longer life .
 - a. baby oil
 - b. coconut oil
 - c. crude oil
 - d. machine oil
7. The correct cloth used in wiping spilled oils during cleaning .
 - a. damp cloth
 - b. dry cloth
 - c. oiled cloth

- d. any of the above
8. The part of the sewing machine that should be avoided during the application of oil.
- bobbin winder
 - rubber ring
 - stitch regulator
 - stop motion screw
9. The cleaning material that maintains moving parts of a sewing machine in smooth operation.
- absorbent cloth
 - lint brush
 - lubricant
 - water
1. A good practice of cleaning and lubricating the sewing machine .
- every two weeks
 - once a week
 - once a month
 - twice a week



What Do You Need To Know?

Read the Information Sheet 1.1 very well then find out how much you can remember and how much you learned by doing Self-check 1.1.

Information Sheet 1.1

Setting of Sewing Machine and Its Troubles

A **treadle sewing** machine works by foot action and doesn't require any electricity. If taken care of properly, an antique treadle sewing machine can sew a better stitch than its modern counterpart can. It takes some practice to keep your treadle machine sewing smoothly, but once you've mastered the foot action, you can enjoy sewing and getting a little exercise at the same time

Treadle Sewing Machine Picture Tour



View of the cabinet with the machine closed.



Cabinet open and the machine in the up position

The machine for more details be sure to see the manual.

Close up of the bobbin winder. Note the heavy brass and the number of connections in this mechanism, compared to today's machines.

View of the end of the machine. Tension mechanism and tread guides.

View of the back of the machine

Close up of the back access panel. This has been damaged by rust but shows the detail.

Close up of the decal. Note the area in the red circle. The japanning has remained in tact but the decal has peeled away leaving bare metal.

Metal Singer emblem and the machine serial number.

SETTING OF SEWING MACHINES

Perfect machine stitching is easy to achieve if you set the machine properly. This involves threading the upper and lower parts of the sewing machine. The beginner in dressmaking must learn how to thread the head of the sewing machine as one of the first steps in becoming a competent operator.

THREADING THE MACHINE

Each part of the threading mechanism on the head of a sewing machine has a definite purpose in guiding the thread from the spool to the needle. The thread must pass through the various guides in a given order so that the machine will sew properly the formed stitches.

A. ORDER OF THREADING IN THE UPPER PART

1. Spool Pin
2. Upper thread guide
3. Between metal disc of tension
4. Thread take up lever
5. Lower thread guide
6. Needle

STEPS:

1. Put the spool of thread on the spool pin.
2. Bring the thread to the thread guide .
3. Pull the thread between the metal disc of the tension.
4. Bring the thread up to the thread take up lever and raise it as it goes.
5. Pull the thread down to the thread guide.
6. Pull it through the lower thread guide.
7. Thread the needle.

B. THREADING THE LOWER PART OF LOCKSTITCH SEWING MACHINE/ or TREADLE SEWING MACHINE

STEPS:

1. Remove the bobbin case by pulling on the bobbin case latch.
2. Remove the bobbin from the case and wind the thread .
3. Put the bobbin back to the bobbin case and pull the thread through the little slot at least 4 inches.
4. Be sure that you hear the bobbin case inside the shuttle.
5. Start the mechanism by rolling the balance wheel forward to get the thread of the bobbin through the needle.
6. Pull the upper and lower thread together by 4 inches.

As you enjoy using your sewing machine , problems cannot be avoided , but knowing its causes is another challenging skill to develop. How can you classify these problems or troubles ?

CLASSIFICATIONS OF SEWING MACHINE TROUBLES

If the sewing machine in your laboratory are kept in good condition and are carefully adjusted and properly threaded , not too many things can go wrong. But there are certain difficulties that occur during an operation so often , so you should know these minor and common problems their causes and remedies. There are two classifications of sewing machine troubles, namely :

1. Minor sewing machine trouble

This refers to problems that arise involving incorrectly attached accessories or supplies , unadjusted tensions , or that requires a little dusting or oiling.

2. Major sewing machine trouble

This involves replacing or removing damage spare parts that made the sewing machine not totally functioning.

COMMON SEWING MACHINE TROUBLES

Machine Troubles	Causes	Remedies
1. Machine runs noisily	<ul style="list-style-type: none"> insufficient oil loose screw thread or dust clogged in the shuttle race. 	<ul style="list-style-type: none"> oil the sewing machine tighten loose screw clean the shuttle race before oiling
2. Machine rotates heavily	<ul style="list-style-type: none"> too tight belt insufficient oil bearings or shuttle race is clogged with dust or thread 	<ul style="list-style-type: none"> change belt if already old oil the arm shaft clean the shuttle race and bearing , then oil
3. Needle thread breaks	<ul style="list-style-type: none"> improper threading tight tension thread too coarse needle blunt set incorrectly presser foot not properly adjusted poor quality thread seam maybe too thick or heavy bobbin case turns fabric is pulled forcibly needle may be bent size of needle tension 	<ul style="list-style-type: none"> check the threading , change the texture of thread and attach the needle properly to the needle bar (flat side of the needle should face the needle bar) . use correct presser foot, check if presser foot is secured and properly fastened if seam is too heavy change needle to correct size check the position of the bobbin case, reset the shuttle race assembly change the bent needle to avoid needle bending, pull the upper and lower threads toward the rear of the presser foot after stitching and cut the threads don't force the fabric, just guide it change the size of needle adjust tension
4. Stitches skip	<ul style="list-style-type: none"> bent needle , dull needle or wrongly attached needle unmatched size of needle or thread to the texture of fabric no enough pressure on the presser foot 	<ul style="list-style-type: none"> change the needle or correct positioning change needle size and thread increase pressure on the presser foot check the threading

	<ul style="list-style-type: none"> • threading maybe incorrect 	
5. Stitches loop	<ul style="list-style-type: none"> • dull needle • improper threading • unbalance tension of the upper and lower threads • defective thread take up lever 	<ul style="list-style-type: none"> • use blunt needle • check the threading; if loops appear under the fabric, check the upper threading; adjust the upper tension regulator; if the loops appear on top of the fabric, check the lower threading; the thread may be inserted in the tension groove of the bobbin ; check also the latch spring of the bobbin case. • balance the tension of both threads • change the thread take up lever spring.
6. Upper thread breaks	<ul style="list-style-type: none"> • Improper threading • Improperly attached needle • Bent or dull needle • Tight upper thread • poor quality thread • unmatched needle 	<ul style="list-style-type: none"> • correct threading • attached the needle correctly • change to blunt needle • reset the upper tension regulator • use good quality thread and thread size or texture
7. Lower or under thread breaks	<ul style="list-style-type: none"> • improper winding of the thread in the bobbin • bent or dull needle • poor quality thread • incorrectly set feed dog • bobbin does not freely turn • too tight bobbin case spring 	<ul style="list-style-type: none"> • winding the thread in the bobbin uniformly • change the needle • use good quality thread • lower the feed dog if the fabric is thin; raise the feed dog if the fabric is thick • check if bobbin is clogged with dirt or thread • loosen the adjusting screw of the bobbin case or adjusting the tension of the upper thread

8. Seams Pucker	<ul style="list-style-type: none"> • too long stitch length for the fabric • tension is too tight • size of needle and thread do not match • too high feed dog adjustment • too heavy pressure on the presser foot 	<ul style="list-style-type: none"> • adjust stitch regulator to correct length • adjust the upper and lower tension regulator • use appropriate size of needle and thread • adjust the height of the feed dog depending on the thickness or thinness of the fabric • lessen pressure on the presser foot
9. Fabric does not move	<ul style="list-style-type: none"> • feed dog not in proper sewing position • stitch regulator not set on zero • too tight pressure on presser foot 	<ul style="list-style-type: none"> • adjust the feed dog to proper sewing position • adjust stitch regulator to desired stitch length • add pressure to presser foot by adjusting the pressure regulator screw
10. Fabric jams in machine	<ul style="list-style-type: none"> • Needle may be too big • Throat plate 	<ul style="list-style-type: none"> • Change the size of needle • Needs round hole plate

STANDARDS FOR SEWING MACHINE OPERATIONS

Observe while using / running sewing machine and list the things that you have noticed. By following correct procedures you will make your work easier, more interesting and challenging. Here are some pointers that you have to follow in the manipulation of your sewing machine:

1. Start with the right tools and supplies. Have your needle, thread, screw driver, pins and scissors ready for use. With tools at hand, you can start working continuously on your machine.



2. Always maintain good working posture. Sit on your back slightly leaning forward. It can prevent body pains after working on your machine.



3. Thread the sewing machine correctly. You can follow the guide book if you have. This will save your time to get a correct threading. Refer to someone to check if you have threaded it properly.

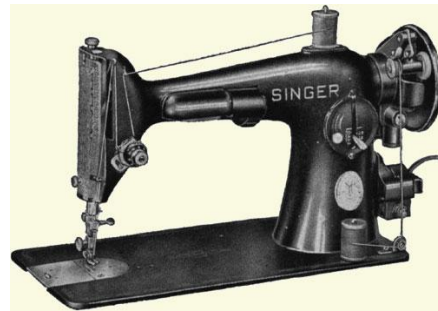

4. Be sure that the needle is properly set according to the directions for specific models. A properly attached needle will make your work without any trouble.



5. Set the stitch regulator according to project specifications and test the stitches for possible adjustments.



6. Check tension dials and adjust according to project requirement of the stitches. A correct adjustment on the tension dials will make perfectly sewn garment.



7. Turn power off (for motorized/electric machines) when the sewing machine is not in use. This will save electricity and avoid possible minor accidents.



8. Keep sewing tools. Dust the sewing machine then put a little amount of machine oil in slots. This will make the sewing machine available for the next user



Note:

The control of the sewing machine lie on your feet not in your hand so learn to start and stop the sewing machine instantly at a given point using this control. Lower the presser foot while sewing but be sure to insert a piece of paper or fabric swatches so that the feed dog will not be worn out.

Getting to stitch

Before you start, make sure the two threads are back between the two toes of the presser foot .

CHARACTERISTICS OF GOOD STITCHES

1. The length of stitch is proportioned to the texture of the fabric.
2. The stitches are the same in length.
3. The stitches appear the same on both right and wrong sides of the fabric.
4. The stitching follows the intended line smoothly and accurately.
5. There are no skipped or broken gaps in stitching.
6. When retraced, it appears as one line of stitching.
7. The stitching has no tangles.

HOW TO MAKE ADJUSTMENT ON THE MACHINE

There are two tension adjustments on the sewing machine the upper and the lower. The upper tension controls the thread from the needle, while the lower tension controls the thread from the bobbin case. These tensions must be adjusted to suit various fabrics. If the tensions on both threads are properly adjusted, the threads will lock at the center of the material and form a correct stitch.

The size of the stitches varies with the type of work being sewed. Thin materials require a short stitch, a light thread, a fine needle, and a tight tension. Heavier materials require a longer stitch, a coarser thread, a larger needle, and less tension.

Sewing machine needles become dull through hard usage and also through ordinary wear; sometimes, they become bent by improper use. The condition of the needle should be checked when sewing difficulties occur. A defective needle should be replaced by a new needle of proper size. A dull needle will show a flat shiny spot at the very tip when rotated between the fingers. The straight of a needle can be tested by

rolling the larger end on a flat surface; bent needles will wobble and straight needles will roll true.

A. HOW TO ADJUST TENSION ON THE NEEDLE THREAD

The stitch tension control determines the amount of tension on the thread as they pass through the machine.

1. Correcting a Loose Top Stitch

When the needle thread tension is too tight, the thread will lie straight along the upper surface.

- Lower the presser foot
- Turn the small thumb nut at the front of the tension discs to the left (counter clockwise) to decrease **the tension**.

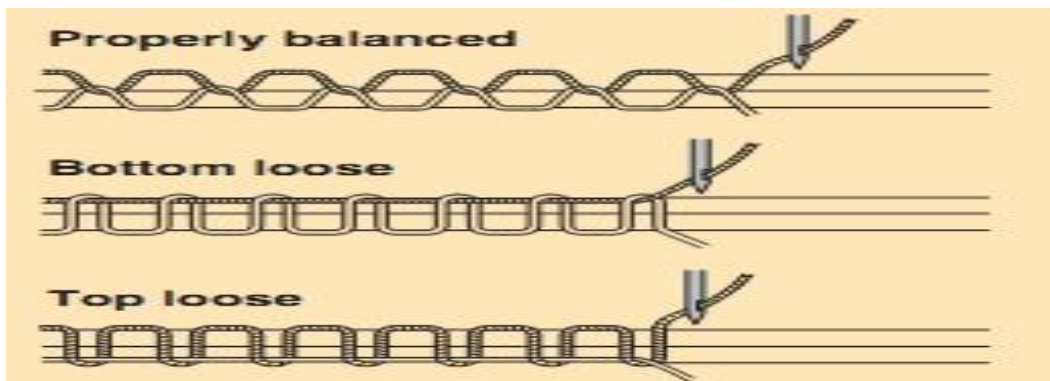

2. Correcting a Loose Bottom Stitch

When the needle tension is too loose , the thread will lie along the underside of the material.

- Lower the presser foot
- Check to make sure that the thread is between the tension discs.
- Turn the small thumb nut at the front of the tension disc (clockwise) to increase the tension.
- Check the stitch on pieces of scrap material.

B. HOW TO ADJUST TENSION ON BOBBIN THREAD

1. Checking Bobbin Case

- Remove the bobbin from the bobbin case.
- Clean the inside of the bobbin case.
Remove all particles of lint and dust with a small point stick.

Note : If the tension spring is bent away from the bobbin case , or if the ends of the spring near the delivery eye are damaged, they should be replaced. Consult your teacher if defective parts are discovered.



2. Adjusting Tension Spring on Bobbin Case

The tension on the bobbin thread is controlled by adjusting the tension spring on the outside of the bobbin case. It is seldom necessary to change this adjustment once the tension has been properly set . The operator will usually be able to correct

the stitch by varying the tension on the needle thread

a. Correcting a loose bobbin thread

If the tension on the bobbin thread is too loose, the needle thread will lie straight along the upper surface of the material.

- Tighten the tension
- Turn the regulating screw in the tension spring to the right.
- Test the tension. Thread the bobbin case. Hold the end of the thread and allow the case to hang freely.
- Check stitch on pieces of scrap material

b. Correcting a Tight Bobbin Thread

If the tension on the bobbin thread will lie straight along the underside of the material.

- Loosen the tension. Turn the regulating Screw in the tension spring slightly to the left.
- Thread the bobbin case and test the tension.
- Check stitches on pieces of scrap material.



HOW TO REGULATE THE LENGTH OF THE STITCH

The length of the stitch is regulated by the stitch regulator on the front side of the head.

- Move the stitch regulator downward to lengthen stitch
- Move the stitch regulator upward to shorten stitch.
- Check the length of stitch on pieces of scrap material.

Note: For normal stitching, set the regulator at 10 to 12 stitches per inch, or at the number 3 for metric scale machines.



HOW TO REGULATE THE PRESSURE ON THE MATERIAL

The pressure on the material is regulated by adjusting screw on the top of the machine.

- Turn the adjusting screw to the right to increase the pressure.
- Turn the adjusting screw to the left to decrease the pressure.
- Check the pressure by stitching on pieces of scrap material of the same weight .

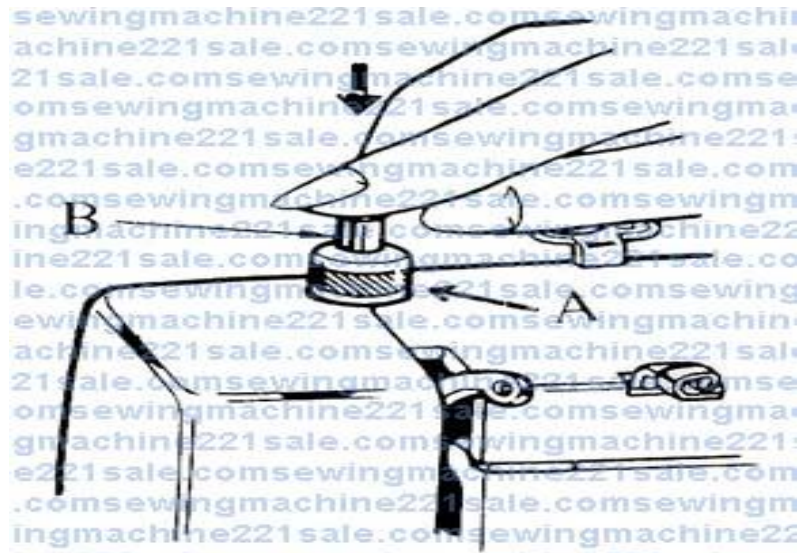

Note: A pressure that is too heavy will cause the machine to run hard and will leave the print of the feed on fine materials.



How Much Have You Learned?

Self-Check 1.1

I. Directions: Write check (y) if the statement is a good characteristic of stitches and cross (X) if it is not. Write your answer in your quiz notebook.

- _____ 1. The stitches have no tangles.
- _____ 2. The stitching follows the intended line smoothly and accurately.
- _____ 3. The length of stitch is not proportioned
- _____ 4. There are skipped or broken gaps in stitching.
- _____ 5. The stitches appear on both right and wrong sides of the fabric.

II. Directions: Arrange the steps in threading the upper and lower parts of the sewing machine. Write number 1 for the first step, 2 for the second step, and so on. Write your answer in your quiz notebook.

A. STEPS IN THREADING THE UPPER PART

- _____ Thread the needle
- _____ Pull it through the lower thread guide
- _____ Pull the thread down on the thread guide.

- _____ Bring thread to the thread guide.
- _____ Pull the thread between the metal disc of the tension.
- _____ Bring the thread up to the lower thread take up lever and raise it as it goes.

B. STEPS IN THREADING THE LOWER PART

- _____ Remove the bobbin case by pulling on the bobbin case latch.
- _____ Pull the upper and lower thread together by four inches.
- _____ Remove the bobbin from the case and wind the thread.
- _____ Start the mechanism by rolling the balance wheel forward to get the thread of the bobbin through the needle.
- _____ Be sure that you hear the case being locked upon inserting the bobbin case inside the shuttle.
- _____ Put the bobbin back to the bobbin case and pull the thread through the little slot at least four inches.

III. Directions: Perform how to start and stop sewing machine following the procedure.



How Well Did You Perform?

Find out by accomplishing the Scoring Rubric honestly and sincerely. Remember it is your learning at stake!

Scoring Rubric

Criteria	Excellent	Very Satisfactory	Satisfactory	Fairly Satisfactory	Needs Improvement	Score
Knowledge	Procedures were followed step 1 to the last	Some of the procedure were omitted	Few of the procedure were not followed	Most of the procedure were not followed	Did not follow any of the procedures	
Speed	Finished ahead of time	Finished on time	Finished but late by three mins	Finished but late for more than 5 minutes	Did not finish	
Assistance required	Did not need assistance	Needed assistance once	Needed assistance twice	Needed assistance four to five times	Needed assistance most of the time	



How Do You Apply What You Have Learned?

Show that you learned something by doing this activity

Activity Sheet 1.1

CONDUCT SAMPLE RUN

Materials:

1. Fabric swatches of silk, denim and cotton
2. Thread
3. Machine Needle – size 14
4. Pair of Scissors
5. Pencil
6. Ruler

INDIVIDUAL TASK:

Prepare swatches of silk, denim and cotton. Stitch on the swatches by stitching straight lines at various stitch length . Test the output and record your observation on the table.

Types of fabric	Length of Stitches	Consistency of Stitches	Tension of Stitches
Silk			
Denim			
Cotton			



How Well Did You Perform?

Find out by accomplishing the Scoring Rubric honestly and sincerely. Remember it is your learning at stake!

Scoring Rubric

Criteria	Excellent	Very Satisfactory	Satisfactory	Fairly Satisfactory	Needs Improvement	Score
Knowledge	Procedures were followed step 1 to	Some of the procedure were	Few of the procedure were not followed	Most of the procedure were not	Did not follow any of the procedure	

	the last	omitted		followed	s	
Speed	Finished ahead of time	Finished on time	Finished but late by three mins	Finished but late for more than 5 minutes	Did not finish	
Assistance required	Did not need assistance	Needed assistance once	Needed assistance twice	Needed assistance four to five times	Needed assistance most of the time	

Activity Sheet 1.2

Materials:

Sewing Machine and Accessories
Sewing Machine Manual

Procedure:

You should follow these steps and see how you can improve your skills but be sure that you already know its parts and functions.

1. Rest both of your feet on the treadle, one ahead of the other.
2. Lift the presser foot before starting the Sewing machine.
3. Start turning the hand wheel towards you applying moderate force in it.
4. When the treadle starts to move, follow its flow, not pushing too much pressure against the treadle.
5. Make five rotations or more until you develop a good control of the sewing machine.
6. Stop your sewing machine by controlling the treadle then hold the band wheel. Practice more as needed.



How Well Did You Perform?

Find out by accomplishing the Scoring Rubric honestly and sincerely. Remember it is your learning at stake!

Items for Evaluation	Suggested Score	Student Score	Teachers' score
Process (70%)			
1.Lifted the presser foot before starting to run the machine.	10		
2.Rested both feet on the treadle on ahead of the other.	10		
3. The balance wheel and applied moderate force.	10		
4. Followed the movement of the treadle and did not exert too much force on it.	10		
5 .Performed four to five rotations continuously.	10		
6. Stopped the machine from running without holding the balance wheel.	10		
Work habits (30 %)			
1. Correct posture was displayed.	10		
2 .Holding of balance wheel was avoided when the machine was in motion.	10		
3. Turning back and forth of balance wheel was avoided.	10		
4 .Followed the procedure correctly.	10		
	10		
Total	100		

Activity Sheet 1.3

Materials

Sewing machine, machine needle, thread,
Fabric swatches, pair of scissors

Instructions: Select a sewing machine to be assessed. Write the information called for in the given form.

DATE		SEWING MACHINE NO.
Trouble	Cause/s	Remedies
MINOR		

1. 2. 3. 4. 5.		
MAJOR		
1. 2. 3. 4. 5.		



How Well Did You Perform?

Find out by accomplishing the Scoring Rubric honestly and sincerely. Remember it is your learning at stake!

Criteria	Excellent	Very Satisfactory	Satisfactory	Fairly Satisfactory	Needs Improvement	Score
Knowledge	Procedures were followed step 1 to the last	Some of the procedure were omitted	Few of the procedure were not followed	Most of the procedure were not followed	Did not follow any of the procedures	
Speed	Finished ahead of time	Finished on time	Finished but late by three mins	Finished but late for more than 5 minutes	Did not finish	
Assistance required	Did not need assistance	Needed assistance once	Needed assistance twice	Needed assistance four to five times	Needed assistance most of the time	



How Do You Extend Your Learning?

Instruction:

In your notebook, draw a lockstitch sewing machine and identify the parts and their functions.

LEARNING OUTCOME 2

Clean and lubricate machine

PERFORMANCE STANDARDS

- Regular cleaning of machine is observed
- Safety procedures in machine cleaning are followed.
- Regular maintenance schedules are observed and recorded.



Materials

1. Sewing machine
2. Damp cloth
3. Machine oil



What Do You Already Know?

Let us determine how much you already know about cleaning and lubricating machine. Take this test.

Pretest LO 2

Direction: Arrange the following steps in chronological order. Mark the first step as **a**, second as **b** and so on. Write your answer on a separate of paper.

A. Face Plate (presser bar, needle bar, thread take up lever, lifter).

- _____ 1. Put back the Face Plate in place
- _____ 2. Unscrew face plate and keep it in the drawer while cleaning.
- _____ 3. Brush dust away then put a little amount of oil while rotating the balance wheel to inner parts can be accessed.

B. Lower mechanism (rotary oscillating hook)

- _____ 1. Put a little amount of machine oil on moving parts
- _____ 2. Remove dust with lint brush
- _____ 3. Fasten sides of oscillating hook
- _____ 4. Return spare parts in place
- _____ 5. Remove bobbin case.

C. Upper tension (Disc Spring and Dial)

- _____ 1. Brush dust and wipe with absorbent cloth with oil
- _____ 2. Remove outer bolt , tension dial , discs and disc spring
- _____ 3. Assemble by following the laid parts in your table
- _____ 4. Lay each part in your front table following its disassembling for easier assembling



What Do You Need To Know?

Read the Information Sheet 1.1 very well then find out how much you can remember and how much you learned by doing Self-check 1.1.

Information Sheet 2.1

Care of Sewing Machine

How to Clean and Oil Your Sewing Machine

Cleaning and oiling your sewing machine is basic maintenance that bits of lint, thread, dust and even fabric can get stuck in your machine. These make work harder and can even jam your sewing machine. Clean your machine to fix these help the machine to last longer and perform more smoothly. If you sew regularly, problems and use sewing machine oil to help the moving parts function smoothly. You should clean and oil your machine after finishing any large project as well as any time you suspect it is having a problem.

INSTRUCTIONS:

1. Prepare the needed tools and supplies in cleaning the sewing machine.
2. Remove the needle if there is any. This will prevent the cleaner from pricking fingers during the cleaning process.

Face Plate (presser bar, needle bar, thread take up lever, lifter).

- Unscrew face plate and keep it in the drawer while cleaning.
- Brush dust away then put a little amount of oil while rotating the balance wheel to inner parts can be accessed.
- Put back the Face Plate in place.



Cleaning and oiling your sewing machine is basic maintenance that can help the machine to last longer and perform more smoothly. If you sew regularly, bits of lint, thread, dust and even fabric can get stuck in your machine. These make work harder and can even jam your sewing machine. Clean your machine to fix these problems and use sewing machine oil to help the moving parts function smoothly. You should clean and oil your machine after finishing any large project as well as any time you suspect it is having a problem.

UPPER TENSION (DISC SPRING AND DIAL)

- Remove outer bolt , tension dial , discs and disc spring.
- Lay each part in your front table following its disassembling for easier assembling.
- Brush dust and wipe with absorbent cloth with oil.
- Assemble by following the laid parts in your table.



LOWER MECHANISM (ROTARY OSCILLATING HOOK)

- Remove bobbin case.
- Fasten sides of oscillating hook.
- Remove dust with lint brush.
- Put a little amount of machine oil on moving parts.
- Return spare parts in place.

OTHER MINOR PARTS

- Remove entangled threads between head and balance wheel.
- Brush accumulated dust in the treadle joints connecting the band wheel.
- Clean gummy dust on the band wheel.
- After all parts were dusted, lubricate all joints and oil slots with good quality oil.
- Wipe off all surplus oil then put a piece of absorbent cloth under the presser foot for dripping oil.

Note : When the machine has thoroughly cleaned and oiled, run it slowly for several minutes to allow the oil to work on its moving parts. Place a scrap of fabric under the presser foot and lower the needle to absorb excess oil.

OCCUPATIONAL HEALTH AND SAFETY PROCEDURE IN SEWING MACHINE MAINTENANCE

Cleaning and lubricating a sewing machine is quite a messy task. Personal care should be observed during this activity. The following health and safety precautions should be practiced at the shop or at home.

1. Wear personal protective equipment. This prevents your clothing from being tarnished by oil and dirt .Be sure to wear gloves to avoid accumulation of oil and dirt in your nails and palms.
(Wearing of protective eye glasses is optional).
2. Remove the upper belt or turn power off before oiling the sewing machine.
3. When a chemical or small spare parts get into your eyes, call the attention of your teacher at once.
4. Do not remove any safety device from any machine.
5. Be sure that all screws are well-lightened before starting the machine.
6. Make sure that no screws or tools are left on the floor to avoid slipping.

7. Wipe dry spilled oils on the floor to avoid accidents.
8. Assign colored tags for a newly maintained sewing machine
9. Provide a small bin for your garbage when performing this job.
10. Have a separate cabinet or storage for tools and supplies for sewing machine maintenance.
11. Always refer to the sewing machine service manual for accurate application of procedure.

Note: A sewing machine is an equipment that needs care and cleaning. Keep it dusted and lubricated at least once a week or more often if the machine is in constant use.



How Much Have You Learned?

Self-Check 2.1

Refer to the Answer Key. What is your score?

A. Directions: Write the letter of the correct answer in your quiz notebook.

1. In wiping spilled oils during cleaning, the correct cloth is _____.
 - a. Damp cloth
 - b. Dry cloth
 - c. Oiled cloth
 - d. Any of the above

2. The part of the sewing machine that should be avoided when oiling is _____.
 - a. Bobbin winder
 - b. Rubber ring
 - c. Stitch regulator
 - d. Stop motion screw

3. The part of sewing machine that can be considered a safety device since it covers the lower mechanism and is important during garment construction is _____.
 - a. bobbin winder
 - b. slide plate
 - c. tension disc
 - d. throat plate

4. The cleaning material that maintains moving parts of sewing machine in smooth operation is _____.
 - a. absorbent cloth
 - b. lint brush
 - c. lubricant
 - d. water

5. The good practice of cleaning and lubricating the sewing machines

- a. Every two weeks
- b. Once a week
- c. Once a month
- d. Twice a week

B. (6-10) Enumerate at least 5 Health and Safety procedure in sewing machine maintenance

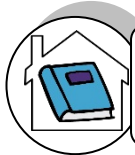

How Do You Extend Your Learning?

Answer the following questions. Write your answers in your assignment notebook.

1. Why is it necessary to keep the machine clean and lubricated ?
2. What is the importance of removing the needle before attempting to clean the machine ?
3. What parts of the machine are to be cleaned and lubricated ?
4. What materials are needed in cleaning the machine properly ?
5. What kind of oil is to be used in lubricating the treadle machine ?



How Do You Apply What You Have Learned?

Show that you learned something by doing this activity

Operation Sheet 2.1

Materials:

Quality oil, lint brush, dry paint brush, screw drivers, pen and record notebook and cotton buds.

Procedures:

- 1 .Remove the needle if there is any.
- 2 . Unscrew face plate and keep it in the drawer while cleaning.
- 3.. Brush dust away and put a little amount of oil on face plate.

4. Put back the face plate in place.
5. Remove outer bolt, tension dial, and disc spring of the upper tension.
6. Brush dust and wipe with absorbent cloth with oil the upper tension.
7. Assemble the upper tension by following the laid parts in your table.
8. Remove bobbin case.
9. Fasten sides of oscillating hook.
10. Remove dust with lint brush.
11. Put a little amount of machine oil on moving parts.
12. Return spare parts in place.
13. Remove entangled threads between head and balance wheel.
14. Brush accumulated dust in the treadle joints connecting the band wheel.
15. Clean gummy dust on the band wheel.
16. Lubricate all joints and oil slots with good quality oil.
17. Put a piece of absorbent cloth under the presser foot for dripping oil.



How Well Did You Perform?

Find out by accomplishing the Scoring Rubric honestly and sincerely. Remember it is your learning at stake!

ITEMS TO BE RATED	RATING SCALE				
	5	4	3	2	1
Procedure were correctly done in sequence.					
Precautions were applied.					
TOTAL SCORE					

Activity Sheet 2.2

Materials: sewing machine, quality oil, lint brush, dry paint brush, screw drivers, cotton buds

Instructions: Group Work

Role Playing: You will be divided into five groups and each group will be given a task to do.

Group I : Prepare the needed tools and supplies in cleaning the sewing machine.

Group II : Clean and lubricate the lower mechanism.

Group III : Clean and lubricate the inner part of the face plate.

Group IV : Disassemble, clean and assemble the upper tension.

Group V. Clean and lubricate other parts of the machine.



How Well Did You Perform?

Find out by accomplishing the Scoring Rubric honestly and sincerely. Remember it is your learning at stake!

Check the column that corresponds to your honest evaluation

ITEMS TO BE RATED	RATING SCALE				
	5	4	3	2	1
1. Ideas were clearly explained in the demonstration.					
2. Procedure were correctly done in sequence.					
3. Precautions were applied and explained.					
4. Cooperation was manifested by the group.					

How to rate your performance:

Refer to the score equivalent to rate your group performance:

16 - 20 = 100%

11 - 15 = 90%

6 - 10 = 85%

0 - 5 = 80%



Congratulations! You did a great job! Rest and relax a while then move on to the next lesson. Good luck!

REFERENCES

- De Cosse, Cy. et al. Singer (Sewing Update). U.S.A. Contemporary Book Inc., 1988.
- De Guzman, Ines A. Technology and Home Economics (First Year). Manila. Saint Bernadette Publications, Inc., 1993.

LESSON 5

Practice Occupational Safety And Health



LEARNING OUTCOMES:

At the end of this Lesson you are expected to do the following:

- LO 1. Identify and evaluate hazards and risks; and**
- LO 2. Control hazards and risks;**



Definition of Terms

Biological - bacteria, viruses, insects, plants, birds, animals, and humans, etc.

Chemical - depends on the physical, chemical and toxic properties of the chemical.

Environment – The circumstances or conditions that surround one

Ergonomic - repetitive movements, improper set up of workstation, etc.,

Exposure – the condition of being exposed, especially to severe weather or other forces of nature

Health - The overall condition of an organism at a given time.

Industry – a specific branch of manufacture and trade.

Injury - Damage or harm done to or suffered by a person or thing

Harmful – Causing or capable of causing harm

Obligations – The act of binding oneself by a social, legal, or moral tie

Physical - radiation, magnetic fields, pressure extremes (high pressure or vacuum), noise, etc,

Protective – giving or capable of giving protection

Psychosocial - stress, violence, etc.,

Responsibility – the ability or authority to act or decide on one's own, without supervision

Safety – Freedom from danger or risk of injury

Textile - A cloth, especially one manufactured by weaving or knitting; a fabric.

Workplace - A place, such as an office or factory, where people are employed

Acronyms

PPE – Personal Protective Equipment

OSH – Occupational Safety and Health

RADHAZ - Radiation Hazard

HERP - Hazards of Electromagnetic Radiation to Personnel

HERO - Hazards of Electromagnetic Radiation to Ordnance

HERF - Hazards of Electromagnetic Radiation to Fuel

LEARNING OUTCOME 1

Identify and Evaluate Hazards And Risks

PERFORMANCE STANDARDS

- Workplace hazards and risks are identified and clearly explained.



Materials

- Safety pins or needle
- Plastic knife
- Cigarette toy
- Chemicals (ask the help of your guardian)
- Instructional manual of sewing machines



What Do You Already Know?

Let us determine how much you already know about identifying and evaluating hazards and risk. Take this test.

Pretest LO 1

Read each item carefully and choose the letter of the best answer from the choices below. Write your answer in your quiz notebook.

1. Any source of potential damage, harm or adverse health effects on something or someone under certain conditions at work.
 - a. Hazard
 - b. Psychological
 - c. Risk
 - d. Chemical

2. The chance or probability that a person will be harmed or experience an adverse health effect if exposed to a hazard. It may also apply to situations with property or equipment loss.
 - a. Psychological
 - b. Risk
 - c. Ergonomics
 - d. None of the above

3. Any substance that can cause harm, primarily to people
 - a. Substance
 - b. Hazard
 - c. Chemical
 - d. Psychological

4. It has recently been acknowledged in legislation as a workplace hazard.
 - a. Risk
 - b. Ergonomics
 - c. Psychological
 - d. Chemical

5. Which of the following is an example of hazard?
 - a. Wet floor
 - b. Flower
 - c. Cake
 - d. baby

Directions: Identify if it is hazards or risks

- | | |
|------------------------------------|------------------------|
| _____ 1. Electricals | _____ 6. Pricks |
| _____ 2. Trips | _____ 7. Knife |
| _____ 3. Spillage of wet substance | _____ 8. Cutting cloth |
| _____ 4. Falls | _____ 9. Cloth dust |
| _____ 5. Scissor | _____ 10. Fire |



What Do You Need To Know?

Read the Information Sheet 1.1 very well then find out how much you can remember and how much you learned by doing Self-check 1.1.

Information Sheet 1.1

What is a hazard?

A **hazard** is any source of potential damage, harm or adverse health effects on something or someone under certain conditions at work.

Basically, a hazard can cause harm or adverse effects (to individuals as health effects or to organizations as property or equipment losses).

Sometimes a hazard is referred to as being the actual harm or the health effect it caused rather than the hazard. For example, the disease tuberculosis (TB) might be called a hazard by some but in general the TB-causing bacteria would be considered the "hazard" or "hazardous biological agent".

What are examples of a Hazard?

Workplace hazards can come from a wide range of sources. General examples include any substance, material, process, practice, etc that has the ability to cause harm or adverse health effect to a person under certain conditions. See Table 1.

Workplace Hazard	Example of Hazard	Example of Harm Caused
Thing	Knife	Cut
Substance	Benzene	Leukemia
Material	Asbestos	Mesothelioma
Source of Energy	Electricity	Shock, electrocution
Condition	Wet floor	Slips, falls
Process	Welding	Metal fume fever
Practice	Hard rock mining	Silicosis

As shown in Table 1, workplace hazards also include practices or conditions that release uncontrolled energy like:

- an object that could fall from a height (potential or gravitational energy),
- a run-away chemical reaction (chemical energy),
- the release of compressed gas or steam (pressure; high temperature),
- entanglement of hair or clothing in rotating equipment (kinetic energy), or
- contact with electrodes of a battery or capacitor (electrical energy).

What is Risk?

Risk is the chance or probability that a person will be harmed or experience an adverse health effect if exposed to a hazard. It may also apply to situations with property or equipment loss.

For example: The risk of developing cancer from smoking cigarettes could be expressed as "cigarette smokers are 12 times (for example) more likely to die of lung cancer than non-smokers". Another way of reporting risk is "a certain number, "Y", of smokers per 100,000 smokers will likely develop lung cancer" (depending on their age and how many years they have been smoking). These risks are expressed as a probability or likelihood of developing a disease or getting injured, whereas hazards refer to the possible consequences (e.g., lung cancer, emphysema and heart disease from cigarette smoking).

Factors that influence the degree of risk include:

- how much a person is exposed to a hazardous thing or condition,
- how the person is exposed (e.g., breathing in a vapor, skin contact), and
- how severe are the effects under the conditions of exposure.

What is a risk assessment?

Risk assessment is the process where you:

- identify hazards,
- analyze or evaluate the risk associated with that hazard, and
- determine appropriate ways to eliminate or control the hazard.

The OSH Answers [Risk Assessment](#) has details on how to conduct an assessment and establish priorities.

What is an adverse health effect?

A general definition of adverse health effect is "any change in body function or the structures of cells that can lead to disease or health problems".

Adverse health effects include:

- bodily injury,
- disease,
- change in the way the body functions, grows, or develops,
- effects on a developing fetus (teratogenic effects, fetotoxic effects),
- effects on children, grandchildren, etc. (inheritable genetic effects)
- decrease in life span,
- change in mental condition resulting from stress, traumatic experiences, exposure to solvents, and so on, and

- effects on the ability to accommodate additional stress.

Will exposure to hazards in the workplace always cause injury, illness or other adverse health effects?

Not necessarily. To answer this question, you need to know:

- what hazards are present,
- how a person is exposed (route of exposure, as well as how often and how much exposure occurred),
- what kind of effect could result from the specific exposure a person experienced,
- the risk (or likelihood) that exposure to a hazardous thing or condition would cause an injury, or disease or some incidence causing damage, and
- how severe would the damage, injury or harm (adverse health effect) be from the exposure.

The effects can be acute, meaning that the injury or harm can occur or be felt as soon as a person comes in contact with the hazardous agent (e.g., a splash of acid in a person's eyes). Some responses may be chronic (delayed). For example, exposure to poison ivy may cause red swelling on the skin two to six hours after contact with the plant. On the other hand, longer delays are possible: mesothelioma, a kind of cancer in the lining in the lung cavity, can develop over 20 years or more after exposure to asbestos.

Once the hazard is removed or eliminated, the effects may be reversible or irreversible. For example, a hazard may cause an injury that can heal completely (reversible) or result in an untreatable disease (irreversible).

Types of Hazard

1. **Chemical** - A chemical hazard is any substance that can cause harm, primarily to people. Chemicals of all kinds are stored in our homes and can result in serious injuries if not properly handled. Household items such as bleach can result in harmful chlorine gas or hydrochloric acid if carelessly used. Gasoline fumes from containers for lawnmowers or boats can result in major health hazards if inhaled.
2. **Electrical** - An **electrical hazard** can be defined as a dangerous condition where a worker could make electrical contact with energized equipment or a conductor, and from which the person may sustain an injury from shock; and/or, there is potential for the worker to receive an arc flash burn, thermal burn, or blast injury.
Working near an electrical hazard is dangerous and can be fatal. Any work on or near energized equipment must be done only when measures are in place to provide protection from electric shock and burn. With adequate safety measures in place, every electrical injury and fatality can be prevented.
An electric hazard is considered to be removed when protective measures are put in place at the source (remove hazard or de energize), or along the path (place electrical insulation/barrier between the worker and the electrical hazard). Where PPE is relied upon for worker protection, **an electrical hazard is considered to remain** and it is still necessary to address safety requirements for other workers in the area.
3. **Ergonomic** - Ergonomic hazards impact employers and workers and their families. Poor workplace design, awkward body mechanics or postures, repetitive

movements, and other ergonomic hazards induce or contribute to a staggering number of cumulative trauma disorders. 2. Cumulative trauma disorders (CTD) affect hands, wrists, elbows, arms, shoulders, the lower back, and the cervical spine area. Structures involved include tendons, muscles, bones, nerves, and blood vessels. One can plan strategies for abatement by learning to recognize the hazards that contribute to CTD. 3. OSHA has published the Ergonomic Program Management Guidelines. OSHA has also given Advance Notice of Proposed Rulemaking for an Ergonomic Standard that will affect all industries. 4. A company wide ergonomic assessment should be developed, followed by a well written ergonomic plan. Ergonomic abatement will decrease the costs associated with CTD and ultimately impact the corporate "bottom line."

4. **Psychological** - The psychosocial hazard has recently been acknowledged in legislation as a workplace hazard. This type of hazard relates to mental health and behavioural disorders.
5. **Radiation** - Radiation Hazard (RADHAZ) describes the hazards of electromagnetic radiation to fuels, electronic hardware, ordinance, and personnel. In the military these hazards are segregated as follows:
 - 1) Hazards of Electromagnetic Radiation to Personnel (HERP)
 - 2) Hazards of Electromagnetic Radiation to Ordnance (HERO)
 - 3) Hazards of Electromagnetic Radiation to Fuel (HERF)
6. **Biological** - A **biological hazard**, or **biohazard**, is anything coming from living organisms (i.e. pollen, fungi, animals, insects, bacteria and viruses) that could be a threat to someone's [health](#). It is represented by ☣, the biohazard symbol, which is used everywhere in the world. When people see this sign they know to take precautions, and to follow proper conduct for science labs.
7. **Physical** - Physical hazards are those substances which threaten your physical safety. The most common types of physical hazards are:

- * Fire
- * Explosion
- * Chemical Reactivity



Hazards may be encountered when using the sewing machine include :

- Cuts and injuries from sharp edges , knife blades, scissors and pins
- Finger injuries while sewing
- Back injury from poor posture and improper lifting procedures
- Eye strain from poor lighting

Safe operating procedure in using the sewing machine

1. Do not use machine unless you had instruction and training in its safe use and operation.
2. Teacher permission must be given to operate the sewing machine .
3. Read and understood the instruction sheet, completed the safety test with 100 %score ,and demonstrated competence and safe use.

Pre- operational Safety

1. Always check that the sewing machine and its cord are in good working order.

2. Check all adjustments and settings carefully before commencing any sewing operation.
3. The workplace should be clean and free of equipment ,rubbish and other obstacles.

Operating Safety Precautions

- Make sure all other students keep away from the workplace at all times.
- One person only is to operate a sewing machine at any time .
- Do not touch a sewing machine while another person is sewing.
- Do not wear loose clothing ,especially long sleeves and neck ties.
- Turn the power off when making adjustments to the sewing machine such as changing the presser foot and needle .
- Never race the sewing machine at high speed .
- Take care not to machine over pins .
- Make sure the take- up lever is in the upper position before pulling out the fabric and cutting threads .
- It is important to keep the machine as free of lint as possible .
- Do not push or pull the fabric while sewing .Let the machine do the work –your hands should guide the fabric without forcing it .



How Much Have You Learned?

Self-Check 1.1

DIRECTION: Enumerate the following

1. Types of Hazards
2. Factors that influence the degree of risk

Refer to the Answer Key. What is your score?



How Do You Apply What You Have Learned?

Show that you learned something by doing this activity

Activity Sheet 1.1

Instructions: Prepare a poster showing the types of hazards

1. Group the students
2. Each group will prepare the poster indicating the types of hazards in a cartolina/ manila paper
3. Present in class the prepared poster.



How Well Did You Perform?

Find out by accomplishing the Scoring Rubric honestly and sincerely. Remember it is your learning at stake!

Items to be Rated	5	4	3	2	1
1. Ideas were clearly explained in the drawing					
2. Cooperation was manifested by the group					
3. Present and explain well the drawing in the class					
4. Neatness of the drawing was observed					

LEARNING OUTCOME 2

Control Hazards And Risks

PERFORMANCE STANDARDS

Occupational Health and Safety (OHS) procedures for controlling hazards and risk are strictly followed.



Materials

Sample of hazardous materials (ask your teacher)



What Do You Already Know?

Let us determine how much you already know about control hazards and risks. Take this test.

Pretest LO 2

A. The garments sector has many hazards that can cause injury to workers. Supply the missing letters to complete the set of word/s.

2. D_ei_g
3. B_l_d_e_ cancer
3. S__st__ce_
4. __ro__c
5. S_e__i__

B. Identify if it is hazards or risks

- | | | |
|-------|-----|-------------|
| _____ | 6.. | Electricals |
| _____ | 7. | Pricks |
| _____ | 8. | Trips |
| _____ | 9. | Knife |
| _____ | 10. | Fire |



What Do You Need To Know?

Read the Information Sheet 1.1 very well then find out how much you can remember and how much you learned by doing Self-check 1.1.

ORGANIZATIONAL SAFETY AND HEALTH AND PROTOCOL

Will exposure to hazards in the workplace always cause injury, illness or other adverse health effects?

Not necessarily. To answer this question, you need to know:

- what hazards are present,
- how a person is exposed (route of exposure, as well as how often and how much exposure occurred),
- what kind of effect could result from the specific exposure a person experienced,

- the risk (or likelihood) that exposure to a hazardous thing or condition would cause an injury, or disease or some incidence causing damage, and
- how severe would the damage, injury or harm (adverse health effects) be from the exposure.

The effects can be acute, meaning that the injury or harm can occur or be felt as soon as a person comes in contact with the hazardous agent (e.g., a splash of acid in a person's eyes). Some responses to may be chronic (delayed). For example, exposure to poison ivy may cause red swelling on the skin two to six hours after contact with the plant. On the other hand, longer delays are possible: mesothelioma, a kind of cancer in the lining of the lung cavity, can develop over 20 years or more after exposure to asbestos. Once the hazard is removed or eliminated, the effects may be reversible or irreversible. For example, a hazard may cause an injury that can heal completely (reversible) or result in an untreatable disease (irreversible).

Hazards and risks in the textiles sector

The textiles sector contains many hazards and risks to workers, ranging from exposure to noise and dangerous substances, to manual handling and working with dangerous machinery. Each processing stage — from the production of materials to the manufacturing, finishing, colouring and Occupational safety and health in the textiles sector packaging —poses risks for workers, and some of these are particularly dangerous for women's health.

Exposure to chemical agents

Many different groups of chemical substances are used in the textiles sector, including dyes, solvents, optical brighteners, crease-resistance agents, flame retardants, heavy metals, pesticides, and antimicrobial agents. They are used in dyeing, printing, finishing, bleaching, washing, dry cleaning, weaving slashing/sizing, and spinning. Respiratory and skin sensitizers can be found in the textiles industry, for example textiles fibres, reactive dyes, synthetic fibres, and formaldehyde. The textile industry has been evaluated as a sector with an increased carcinogenic risk. Several studies have showed an increased risk of nasal, laryngeal and bladder cancer in women.

Exposure to dusts and fibres

The exposure of workers to dusts from material such as silk, cotton, wool, flax, hemp, sisal, and jute can occur during weaving, spinning, cutting, ginning, and packaging. Division of tasks along gender lines may mean that women are exposed to organic dusts more than men, with respiratory diseases being diagnosed more often in women than men. Exposure to fibres and yarns may cause nasal or bladder cancer .

Exposure to biological agents

In some activities, such as carding and willowing, workers may be exposed to

biological agents such as anthrax, clostridium tetanus (the causative agent for tetanus), and coxiella burnetti (which causes Q fever). Exposure to biological agents can result in allergies and respiratory disorders.

Exposure to physical agents

Workers may be exposed to noise and vibrations, for example during weaving, spinning, sewing, twisting, and cutting. Exposure to loud noise can result in permanent hearing damage such as noise-induced hearing loss and tinnitus. Exposure to vibration, particularly together with risk factors for MSDs, can lead to long-term harm. Electromagnetic fields may also be found

in some workplaces in the textiles sector. Accidents in the textiles sector. The textiles sector has many hazards that can cause injury to workers, from transport in the workplace (lift truck), dangerous large work equipment and plant, to the risk of slips from a wet working environment. Workers being struck by objects, such as moving machinery parts and vehicles are a

significant cause of injury in the sector. There also exists the risks of fire and explosions, for example from heating plants used for vapour generation.

Psychosocial issues in the textiles sector. Work-related stress has been defined as being experienced when the demands of the work environment exceed the workers' ability to cope with or control them. Work-related stress may be an issue in some areas of the textiles sector, being associated for example with repetitive and fast paced work, and where the worker has no influence on how the job is done.

Hazard Management

One of the most important duties required by OHS law of all workers, including volunteers, is to keep the workplace as safe as possible. A good way to do this is to use the 4 'SAFE' steps:

Spot the hazard
Assess the hazard
Fix the hazard
Evaluate the result



How Much Have You Learned?

Self-Check 2.1

Refer to the Answer Key. What is your score?

Directions: Identify if it is hazards or risks

- | | |
|------------------------------------|------------------------|
| _____ 1. Electricals | _____ 6. Pricks |
| _____ 2. Trips | _____ 7. Knife |
| _____ 3. Spillage of wet substance | _____ 8. Cutting cloth |
| _____ 4. Falls | _____ 9. Cloth dust |
| _____ 5. Scissor | _____ 10. Fire |



How Do You Apply What You Have Learned?

Show that you learned something by doing this activity

Activity Sheet 2.1

Film Viewing:

1. View any film that is related to Hazard / Risk in a workplace.
2. Make a reaction paper regarding the film.
 - A. <http://www.youtube.com/watch?v=aB2H3qmO1YQ>
 - B. <http://www.youtube.com/watch?v=jmaZBTMzkoY>
 - C. <http://www.youtube.com/watch?v=Vy5oe-CLvmk>
 - D. <http://www.youtube.com/watch?v=HSa71gZbTgQ>

Guide Questions:

1. What is the video all about?
2. Have you seen any hazard or risk in the video? What are these?
3. Do you believe the dressmaker handled her task well as seen in the video? Defend your answer.
4. What will be the role of a dressmaker in this type of possible hazard?



How Well Did You Perform?

Find out by accomplishing the Scoring Rubric honestly and sincerely. Remember it is your learning at stake!

	No. of Points	My Score
Clarity of ideas	10	
Evidence of critical thinking	20	
Coherence of ideas	10	
TOTAL	40	

Read the Information Sheet 2.2 very well then find out how much you can remember and how much you learned by doing Self-check 2.2

Information Sheet 2.2

CONTINGENCY MEASURES AND PROCEDURES

Safety in the Sewing Room

Note: This is an excellent article on sewing room and craft room safety with some wonderful ideas for safe storage along with guidelines on how to use common tools and items found in your sewing and craft room.

When my mother first started teaching me to sew, she told me about one of her earliest sewing mishaps. She was about five years old, and was playing with her mother's treadle machine (even though she knew she wasn't allowed to). Sure enough, she turned the flywheel while her finger was under the needle. But she knew if she cried out, she would be punished for playing with the machine, so she had to back the needle out and bandage the wound herself. Her mother never found out about the accident, and my mother never had another machine mishap again.

Mom's story made a big impression on me; I have always been a cautious sewer. So far (knock wood!) I have avoided any serious sewing injury, but thousands of other sewing enthusiasts every year are not as fortunate.

Sewing involves lots of opportunities for injury. Some of these are obvious, but some are less so. Sewers can injure their bodies in almost imperceptible ways.

The most obvious injuries are those caused by sharp implements, such as needles and cutting tools. In addition to puncture wounds, sewers are at risk for slicing wounds (from scissors and rotary cutters) and burns (from irons). Taking basic precautions will reduce the risk of injury in the sewing room.

How to Avoid Injury Using a Sewing Machine

Sewing machines make quick work out of piles of mending, but many people take for granted that a sewing machine is a potentially harmful instrument! Each year people accidentally harm themselves at home or at work while sewing on a machine. Here are a few guidelines to minimize your chance of injury.

1. Examine the sewing machine to make sure that it is fully assembled and well maintained. Depending on your model of sewing machine or serger, the manufacturer has guards on various parts of the machine. Make sure that these guards are fully in place before using the machine.
2. Evaluate the ergonomics of your workspace. Is your chair ergonomically correct in terms of height, tilt, back support, etc.? Do you need a footrest? Does your chair or stool adjust? proper furniture can go a long way in combating repetitive stress disorders such as carpal tunnel syndrome.
3. Clear your surroundings of clutter and debris. Besides the psychological stress of a cluttered workspace, sewing machines can overheat. Extra flammable materials in your work area increase the danger. Also, extra threads, scraps, etc., can become lodged in moving parts, causing jams or unpredictable operation.
4. Turn on a light. Eyestrain is a common injury for anyone performing the fine detail work of sewing. Good lighting also helps reduce the chance of unwanted material being drawn into the machine.
5. Follow the instructions! Take some time to familiarize yourself with the sewing machine, as well as the manufacturer's recommended best practices.
6. Wear protective eyewear. You could accidentally sew over a pin or break a needle. Why take the chance of an eye injury?
7. Learn how to sew correctly. Improper habits such as sewing over the same area repeatedly can lead to needle breakage or trip other hazards.
8. Avoid using fingers to feed fabric into the machine. Develop healthy habits of keeping fingers away from the feeder, as well as using chopsticks to hold fabric up close.

Employer OHS obligations

Employers and management have responsibilities to:

- provide a safe environment to work in, for example, safe equipment , Materials and safe ways to work
- provide information, instruction, training and supervision to employees as needed to ensure they can work as safely as possible
- identify unsafe situations before problems arise, and take corrective action

to make them as safe as possible

- take action to investigate any accidents, and to prevent them from happening again
- ensure that the work done does not cause harm to any person

Your OHS obligations

Employees have duties that support the employer, and provide responsibility for things they have control over.

Employees have responsibility to:

- obey all reasonable safety instructions
- take reasonable care of their own health and safety, and for the safety of others in the workplace
- report any dangerous situation
- work with the employer to improve safety at the workplace.

Safety Groups

Most workplaces have people or groups of people with specific roles relating to Workplace Health and Safety. For example there may be:

- *Health and safety representatives*
- *Supervisors*
- *Safety Officers*
- *Health and Safety Committees*

1. Health and safety representatives

Health and safety representatives are the important links between employees and employers. Health and safety representatives are people elected by co-workers to act on their behalf, telling employers about safety and health concerns and cooperating with employers to implement and maintain workplace health and safety.

2. Supervisors

Supervisors need to make sure that the people they are looking after are given the safety instructions they need, and are able to perform their jobs safely.

Portfolio record - OHS organizations

If you are planning to apply for RCC you need the information gained from the learning activities you undertake. Wherever you see this icon there will be an action needed in the Work Record Portfolio.

Complete OHS organizations in the Work Record Portfolio.

3. Safety Officers

Safety officers are trained people who are hired by the employer to help with the management of health and safety at the workplace. Some of the tasks Safety Officers may do are:

- organize OHS trainings
- investigate accidents
- provide first aid
- do risk assessments at the workplace.

4. Health and Safety Committees

Health and safety committees bring together workers, managers and representatives of other important groups to help improve safety at the workplace. Health and Safety Committees can assist with health and safety planning, and in the development of safety plans, procedures and documentation. They can also serve as a good place for discussion, and can recommend solutions to more complex OHS problems.

Safety committees can be formed at the request of the employees at the workplace, or an employer can organize to help form one.

What are the legal requirements for personal protective equipment (PPE)?

PPE should be provided to workers wherever there are health (or safety) risks that cannot be adequately controlled in other ways. PPE can reduce or prevent a worker's exposure to a health hazard in the workplace and can include respirators, hearing protectors, protective clothing, footwear, face and eye shields.

PPE is also required in specific situations and dealt with in regulations made under OSHA.

How can the risks posed by health hazards be controlled?

The best methods of controlling exposure to a particular hazard will depend on what it is. In general, methods of control can be placed in four categories:

Engineering controls are methods of designing or modifying plants, processes and equipment so as to minimize workers' exposure to the hazard. They are preferred because they work independently of workers.

- Work and hygiene practices are on-the-job activities that reduce the potential for exposure.
- Administrative controls are things like job rotation schedules, work-rest cycles and timing of maintenance procedures, which can be used to limit the amount of time an individual is exposed to a hazard.
- Personal protective equipment includes items like respirators, hearing protectors, safety clothing and protective clothing. It can reduce a worker's exposure but must be used properly to be effective.

Employers

Employers have the duty to provide appropriate protective wear. There are some exceptions, for instance some soft-toe protective footwear and prescription safety glasses, which the employee may be expected to provide. The employer must ensure that the PPE is clean and fit for purpose. She must ensure that it is replaced if it is worn or damaged. If the employee needs to be trained to use it, she must ensure that he is given this training.

Employee

The employee has a duty to wear PPE correctly when she is required to do so. She should report any damage to it, though she should not have to pay for this. She should also attend any training provided on how to correctly wear or use PPE.

CONTINGENCY PLAN

A **contingency plan** is a plan devised for an exceptional risk that, though unlikely, would have catastrophic consequences. Contingency plans are often devised by governments or businesses. For example, suppose many employees of a company are traveling together on an aircraft which crashes, killing all aboard. The company could be severely strained or even ruined by such a loss. Accordingly, many companies have procedures to follow in the event of such a disaster. The plan may also include standing policies to mitigate a disaster's potential impact, such as requiring employees to travel separately or limiting the number of employees on any one aircraft.



How Much Have You Learned?

Self-Check 2.2

Answer the following questions:

1. How to avoid injury using a sewing machine?
2. How can the risks posed by health hazards be controlled?



How Do You Extend Your Learning?

Responsibility for safety

Instructions:

Find out about anyone in your school or in the community who has a specific responsibility for safety. You may need to ask someone, teacher/mentor. In your notebook, write down the information.



Congratulations! You did a great job! Rest and relax a while then move on to the next lesson. Good luck!

REFERENCES

http://www.ccohs.ca/oshanswers/hsprograms/hazard_risk.html

www.dehp-facts.com/CLab/CL_hazard.htm

ANSWER KEYS

LESSON 1: USE OF SEWING TOOLS

LO1. Identify sewing tools and equipment and their uses.

PRE-TEST:

1. C
2. A
3. D
4. C
5. B
6. C
7. A
8. A
9. A
10. A

SELF-CHECK 1.1

1. Spool pin
2. Presser foot
3. Presser bar lifter
4. Arm
5. Stitch regulator
6. Thread take up lever
7. Needle Clamp
8. Upper tension regulator
9. Feed dog
10. Stop Motion Screw
11. Balance Wheel
12. Belt
13. Leg
14. Treadle
15. Bed
16. Throat plate
17. Band Wheel

LESSON 2: CARRY OUT MEASUREMENTS AND CALCULATIONS

LO1. Obtain measurements

PRE-TEST

1. A
2. B
3. B
4. C
5. B
6. A
7. D
8. C
9. B
10. D

SELF-CHECK 1.1

1. A
2. B
3. B
4. C
5. C
6. Desired length
7. Breast or bust / shoulder blade
8. Arm girth
9. Leg hole
10. Seat

LO2 Perform Simple Calculations

PRETEST

1. A
2. C
3. C
4. A
5. D
6. 12.7 centimeters
7. $1\frac{1}{4}$
8. 22.86
9. 1 yard
10. 4.572 meter

SELF-CHECK 2.1

1. 2.5 inches
2. Addition, Subtraction, Multiplication, Division
3. 5.08 centimeters
4. 3810
5. Calculator
6. 1 yard
7. $\frac{1}{2}$
8. $\frac{3}{4}$
9. 2
10. 58 $\frac{1}{2}$

LO3 Estimate Appropriate Quantities

Key Answer # 4.1Quantity	Materials	Unit Price	Total Cost
$\frac{1}{2}$ yard	Cacha (45" width)	55.00	27.50
$\frac{1}{4}$	Manila paper	7.00	2.00
1spool	Thread (small)	5.00	5.00
			Total Cost = 34.50

2.

Quantity	Materials	Unit Price	Total Cost
2 yards	Cacha (45" width)	55.00	110.00
1	Manila paper	7.00	7.00
2 spool	Thread (small)	5.00	10.00
			Total Cost = 127.00

LESSON 3: CREATE DESIGN FOR A SIMPLE PROJECT

LO1. Sketch simple project design

PRE-TEST

A.

1. balance
2. formal balance
3. informal balance
4. proportion
5. formal balance
6. emphasis
7. rhythm
8. gradation
9. harmony
10. radiation

B.

1. red
2. orange
3. red-violet
4. pink
5. shade
6. yellow-green & blue-green
7. blue
8. blue-green & yellow-green
9. green & orange
10. white, black & gray

SELF-CHECK 1.1

1. Formal balance
2. Proportion
3. Emphasis
4. Gradation
5. Harmony

SELF-CHECK 1.2

- | | |
|---------------|-------------------------------|
| 1. Blue | 6. Blue-green and blue-violet |
| 2. Green | 7. Green |
| 3. Red-orange | 8. Red-violet and blue-violet |
| 4. Pink | 9. Green and violet |
| 5. Shade | 10. White, black and gray |

LO2. Produce simple project

PRE-TEST

A.

1. back stitch
2. basting
3. running stitch
4. blanket stitch
5. catch stitch
6. chain stitch
7. outline stitch

B.

- 7 Remove hanging threads.
- 3 Zigzag raw edges of the pockets.
- 5 Fold and baste of the organizer before sewing in the sewing machine.
- 8 Press.
- 6 Lay the pockets, pin, baste then machine stitch.
- 2 Put labels for each pockets as marking tools, measuring tools and cutting tools.
- 4 Sew the handles for hanging.
- 1 Work on the pockets by putting designs applying the principles of designs.

SELF-CHECK 2.1

1. Chain Stitch
2. Catch stitch
3. Back stitch
4. Running stitch
5. Blanket stitch
6. Hand stitch
7. Machine stitch
8. Pin stitch
9. Basting edges stitch
10. Outline stitch

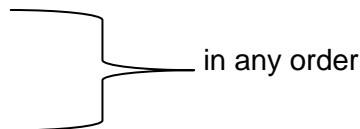

SELF-CHECK 2.2

- 7 Remove hanging threads.
- 3 Zigzag raw edges of the pockets.
- 5 Fold and baste of the organizer before sewing in the sewing machine.
- 8 Press.
- 6 Lay the pockets, pin, baste then machine stitch.
- 2 Put labels for each pockets as marking tools, measuring tools and cutting tools.
- 4 Sew the handles for hanging.
- 1 Work on the pockets by putting designs applying the principles of designs.

LESSON 4: PERFORM BASIC MAINTENANCE

LO1. Operate machine and assess its performance

PRE-TEST

1. d
2. a

3. b
4. c
5. b
6. a
7. d
8. d
9. b
10. d

LO2.
PRE-TEST

A.

1. c
2. a
3. b

B.

1. d
2. c
3. b
4. e
5. a

C.

1. c
2. a
3. d
4. b

SELF-CHECK 2.1

1. A
2. B
3. C
4. B
5. C

6-10 Refer your answer on pages 90-91

SELF-CHECK 3.1

I.

1. Y
2. Y
3. X
4. X
5. Y

II. A. STEPS IN THREADING THE UPPER PART

- 6 Thread the needle
- 5 Pull it through the lower thread guide
- 4 Pull the thread down on the thread guide.
- 1 Bring thread to the thread guide.
- 2 Pull the thread between the metal disc of the tension.
- 3 Bring the thread up to the lower thread take up lever and raise it as it goes.

B. STEPS IN THREADING THE LOWER PART

- 1 Remove the bobbin case by pulling on the bobbin case latch.
- 5 Pull the upper and lower thread together by four inches.
- 2 Remove the bobbin from the case and wind the thread.
- 6 Start the mechanism by rolling the balance wheel forward to get the thread of the bobbin through the needle.
- 4 Be sure that you hear the case being locked upon inserting the bobbin case inside the shuttle.
- 3 Put the bobbin back to the bobbin case and pull the thread through the little slot at least four inches.

LESSON 5: PRACTICE OCCUPATIONAL SAFETY AND HEALTH

LO1. Identify and evaluate hazards and risks

PRE-TEST 2.1

I.

1. A
2. A
3. C
4. C
5. A

- III.
- | | |
|------------|------------|
| 1. Hazards | 6. Risks |
| 3. Risks | 7. Hazards |
| 4. Hazards | 8. Risks |
| 5. Risks | 9. Risk |
| 6. Hazards | 10. Risk |

SELF-CHECK 1.1

1. Types of Hazards

Physical	Psychological
Chemical	Electrical
Ergonomical	Biological

2. Factors that influence the degree of risk.

- how much a person is exposed to a hazardous thing or condition,
- how the person is exposed (e.g., breathing in a vapor, skin contact), and
- how severe are the effects under the conditions of exposure.

SELF-CHECK 1.2

1. Hazards	6. Risks
7. Risks	7. Hazards
8. Hazards	8. Risks
9. Risks	9. Risk
10. Hazards	10. Risk

LO2. Control hazard and risks

1. D
2. C
3. E
4. A
5. B

PRE-TEST LO2

1. dyeing
2. bladder cancer
3. substances
4. chronic
5. swelling
6. hazard
7. risks
8. risks
9. hazard
10. risk

SELF CHECK 2.1

Answer the following questions:

11. How to avoid injury using a sewing machine?

- Examine the sewing machine to make sure that it is fully assembled and well maintained.
- Make sure that these guards are fully in place before using the machine.
- Evaluate the ergonomics of your workspace.
- Clear your surroundings of clutter and debris.
- Turn on a light. Eyestrain is a common injury for anyone performing the fine detail work of sewing.
- Follow the instructions
- Wear protective eyewear.
- Learn how to sew correctly.
- Avoid using fingers to feed fabric into the machine.

12. How can the risks posed by health hazards be controlled?

- Work and hygiene practices are on-the-job activities that reduce the potential for exposure.
- Administrative controls are things like job rotation schedules, work-rest cycles and timing of maintenance procedures, which can be used to limit the amount of time an individual is exposed to a hazard.
- Personal protective equipment includes items like respirators, hearing protectors, safety clothing and protective clothing.

Acknowledgement

This Learning Module was developed for the Exploratory Courses in Technology and Livelihood Education, Grades 7 and 8 of the K to 12 Curriculum with the assistance of the following persons:

This Learning Module on **DRESSMAKING / TAILORING NC II** was developed by the following personnel:

MODULE WRITERS

DOMINGA CAROLINA F. CHAVEZ

*Principal II, MBHS
Muntinlupa City*

NENA T. PINEDA

*TLE-HE Teacher 3
Olongapo City National High School
Olongapo City - Region III*

MA.GLENDA M. MENDOZA

*TVE Coordinator
Muntinlupa Business High School
Muntinlupa City*

REVIEWERS

GIL P. CASUGA

Chief TESD Specialist

REYNALDO S. DANTES

Senior TESD Specialist

MARIA A. ROQUE

Senior TESD Specialist

BERNADETTE S. AUDIJE

Senior TESD Specialist

VICTORIO N. MEDRANO

Principal IV, SPRCNHS

PARALUMAN R. GIRON, Ed.D.

Chair, Sub-TWG on K to 10

BRENDA B. CORPUZ, Ph.D.

TA for K to 12 Curriculum

OFELIA O. FLOJO

Retired Assistant Chief, EED, Region IV-A

BEATRIZ A. ADRIANO

Principal IV, ERVHS

AIDA T. GALURA

VSA II, ACNTS

DOMINGA CAROLINA F. CHAVEZ

Principal II, MBHS

DOCUMENTORS / SECRETARIAT

PRISCILLA E. ONG

K to 12 Secretariat

FREDERICK G. DEL ROSARIO

Head Teacher III, BNAHS

EMMANUEL V. DIONISIO

Head Teacher III, AFGBMTS

LYMWEL P. LOPEZ

Teacher I, AFGBMTS

DANTE D. VERMON JR.

Teacher I, AFGBMTS

ROMANO T. LOPEZ JR.

Teacher I, AFGBMTS

JOANNA LISA C. CARPIO

Teacher I, BNAHS

LOUIE ANGELES

Teacher I, BNAHS

Dir. IMELDA B. TAGANAS

*Executive Director, Qualifications Standards Office
K to 12 Learning Area Team Convenor, TLE/TVE*

